

AF 0020

SEMI AUTOMATIC LIQUID FILLING MACHINE

The AF 0020 twin head filler offers small to medium scale filling operations with an unparalleled flexibility for filling a wide range of products.

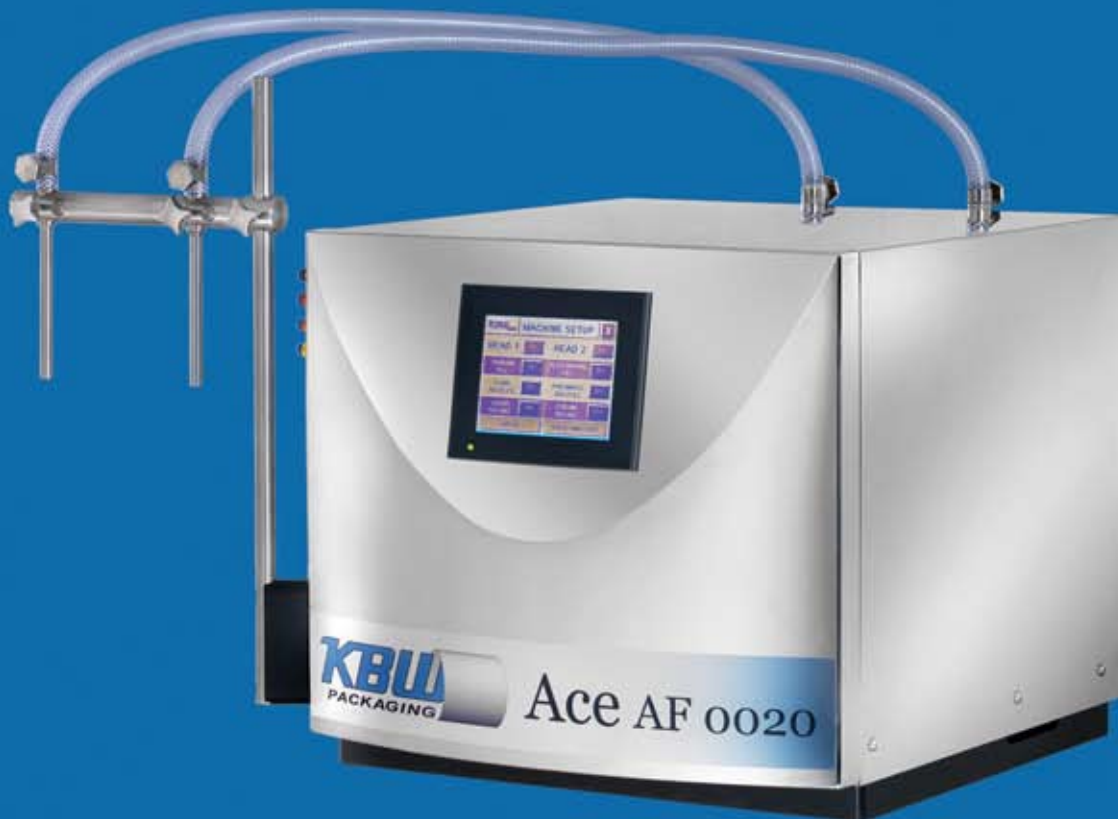

MACHINE FEATURES

- 5.1" menu driven touch screen interface.
- Accurate and repeatable servo filling technology.
- Complete nozzle range to suit all filling media.
- Fully controllable 4 stage profile filling.
- Simple operation with fast product change over.
- Tool free removable product change parts.
- Multiple adjustments without the need to stop the machine.
- Constructed in compliance with FDA approved materials.
- Optional full IQ/OQ Validation support documentation.
- Small machine footprint.

YOUR PARTNER IN PACKAGING

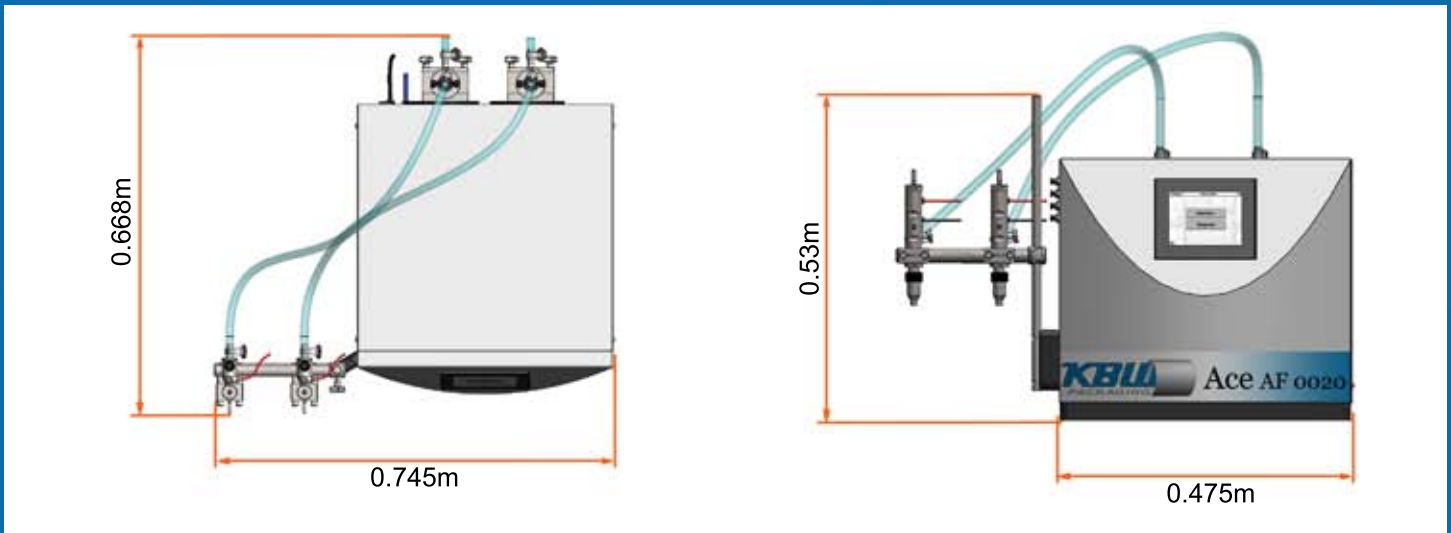

TECHNICAL SPECIFICATION

Filling Range:	2ml - 5L.
Filling Accuracy:	+/- 0.5%
Filling Speed:	Operator(s) Dependent
Filling Technology:	Volumetric
Electrical Control System:	Schneider Electric (Elau)
Pneumatic Components Build:	Festo
Build Standard:	cGMP, CE marked in accordance with Machinery Directive 2006/42/EC
Electrical Requirements:	220/240V 50 Hz 1Ph 110/120V 60 Hz
Pneumatic Requirement:	4 - 7 Bar, filtered and dried
Nett Weight:	63Kg

OPERATION

The AF 0020 is operated using an HMI where the dose and product flow rate can be adjusted along with single shot and profile filling modes. When filling begins liquid is pumped under pressure past a non return valve and out of the dispensing nozzle.

Filling is a pre determined value. When the correct number of pulses given by the pump drive is reached the pump head stops and the filling cycle is complete. The operator then manually changes the bottles over and initiates the next filling cycle using either an optional foot switch or a preset time delay operation.