

AF 0080

FULLY AUTOMATIC LIQUID FILLING MACHINE

The AF 0080 in-line volumetric liquid filler offers high speed filling with unparalleled flexibility to suit a number of industries.

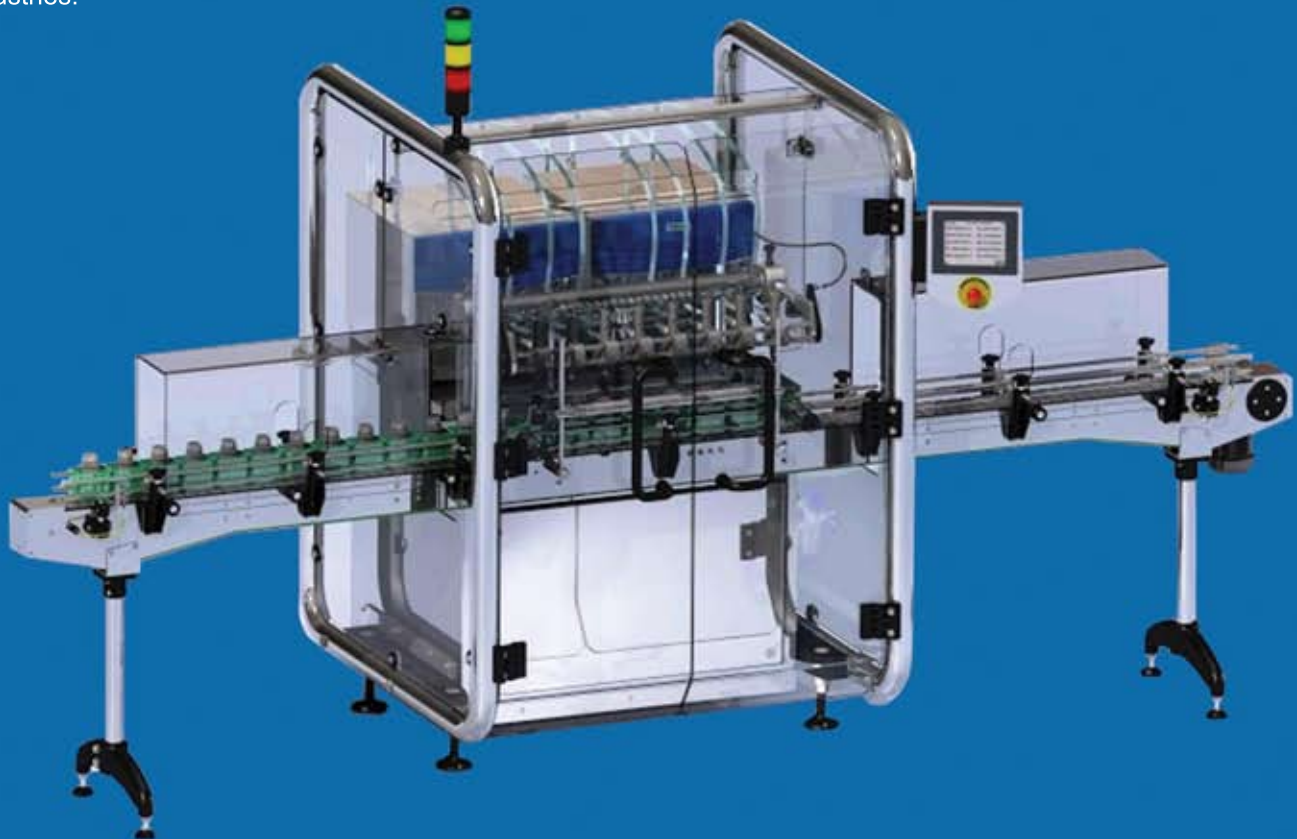

MACHINE FEATURES

- 7.5" TFT colour touch screen capable of storing up to 200 recipes.
- Programmable for multi speed and profile filling cycles.
- Complete nozzle range to suit all filling media.
- Fast and accurate servo driven nozzle lift.
- Toolless quick release machine elements.
- Positive container neck locator.
- Sealed base cabinet.
- Accurate and repeatable servo filling technology.
- Multiple adjustments without the need to stop the machine.
- Smooth and accurate container handling.
- Fast product changeovers.
- Integrated fault alarms.
- Constructed in compliance with FDA approved materials
- Optional full IQ/OQ validation support documentation

YOUR PARTNER IN PACKAGING

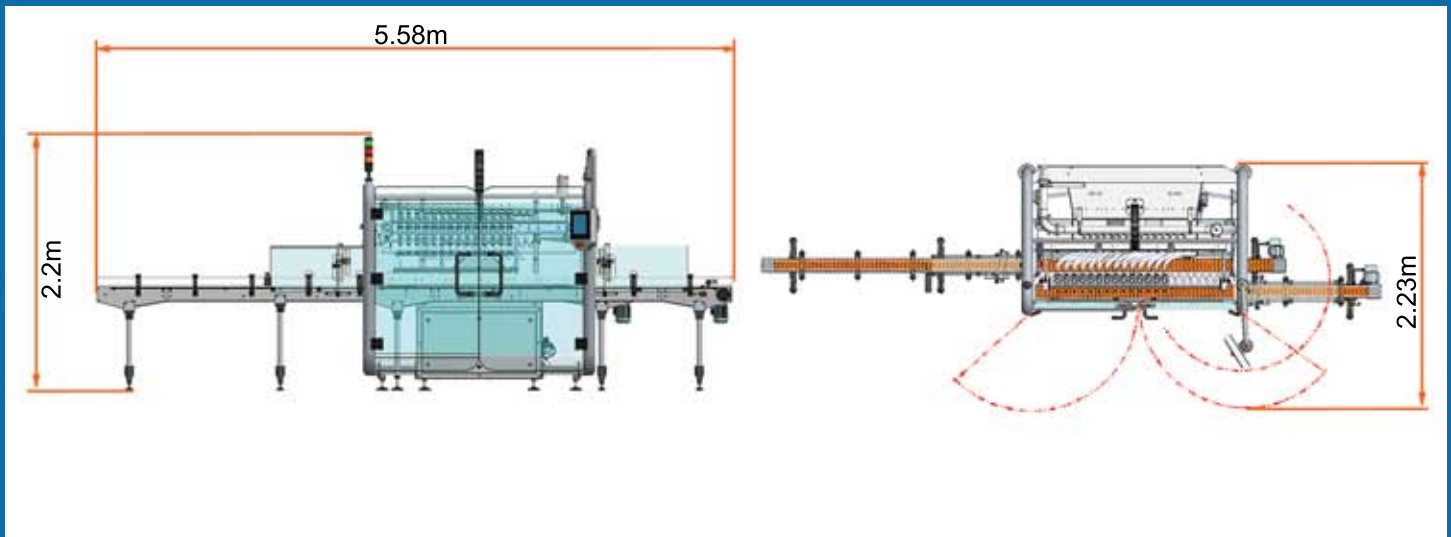

TECHNICAL SPECIFICATION

Filling Range:	10ml - 5L
Filling Accuracy:	+/- 0.5%
Filling Speed:	Up to 80 bottle per minute (Dependent on fill and bottle size)
Filling Technology:	Volumetric
Build Standard:	cGMP, CE marked in accordance with Machinery Directive 2006/42/EC
Power Requirements:	220/240V 50Hz 1Ph or 110/120V 60Hz
Pneumatic Requirement:	4 - 7 Bar, filtered and dried
Nett Weight:	750Kg

OPERATION

The AF 0080 is controlled using a Touch Screen Interface. Each product is stored in a recipe format for quick and easy recall. The filling cycle commences as soon as the bottles have correctly entered the filling area, the neck locator then extends to locate the bottles.

The nozzle bar lowers the dispensing nozzles into the prepositioned bottles. The nozzle valves open allowing liquid to be dispensed under pump pressure. Once the correct number of pulses given by each pump drive is reached each pump head stops and all dispensing valves close. When the filling cycle is complete, the bottle changeover occurs allowing the cycle to be repeated.

If faster outputs are needed the AF 0120 would be the next step up from the AF 0080 8 head. The AF 0120 is a 12 head volumetric filler and has the ability to achieve outputs of up to 150 bottles per minute. For further details please contact our sales team.

www.kbw-packaging.com