



TORNADO EVO

for liquids - semi liquids - powders - solids - wet tissue



technical data	max reel width	600 / 900 / 1200 mm (reel width / 2 / sachet width = n° production lanes)
	max reel diameter	600 mm
	sachet width	min. 25 / 40 mm - max. 150 mm
	max sachet length	250 mm
	voltage	400 V + N + PE
	installed power	20 Kw
	average absorption	3 - 4 Kw
	output speed	in excess of 4000 sachets/min.
dimensions [max]	2800 x 2260 x 2210 mm	

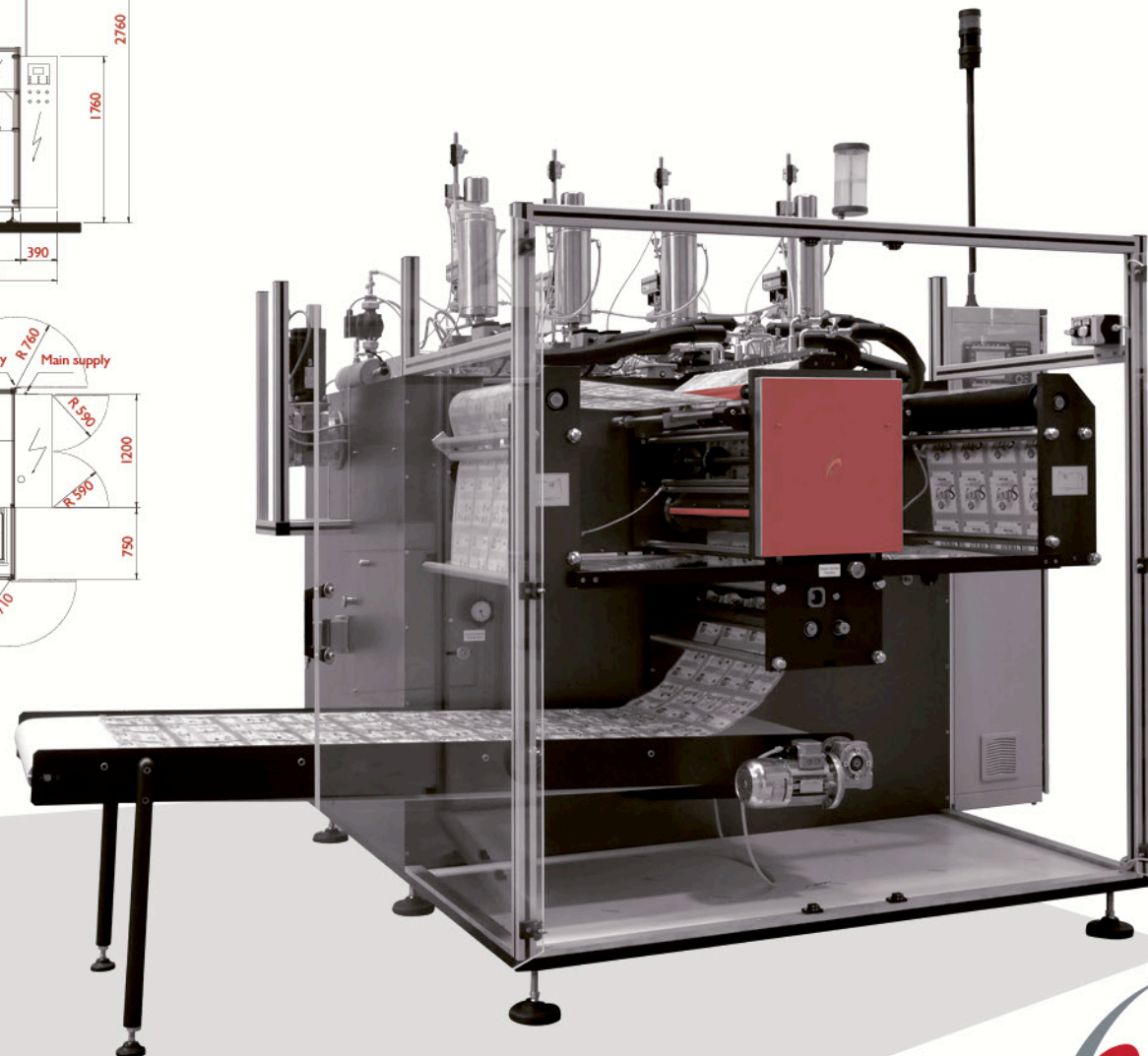
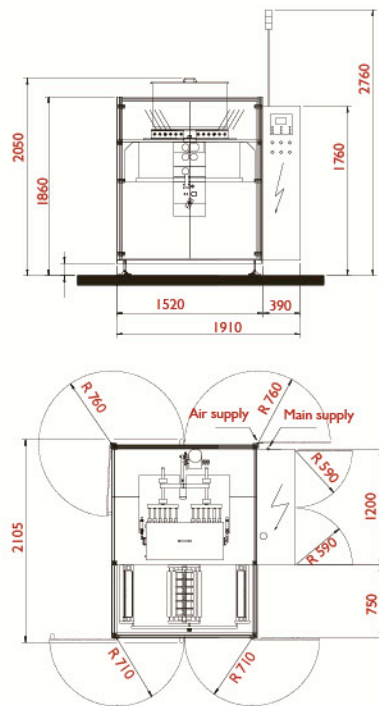

Technical documentation [DQ., IQ., OQ., PQ., FDS, RA, FAT, TM, OPP, etc...] available on request.
 For descriptions in other languages, please refer to our website: www.boatopack.com
 Technical data, like power and air consumption, depends on the machine + doser + optional configuration, this info will be supplied with the project quotation.

AUTOMATIC HIGH SPEED and FLEXIBLE multilane sachet machine for the forming and filling of 4 side seal sachets. The **TORNADO-EVO** has been developed with the idea to improve the already well consolidated and successful features of the existing Tornado machine. Thanks to the extensive utilization of servomotor technology, the last limitations [manual adjustment of jaws speed variation, range limit of the **BPMBS®**] have been removed. The core of the new TORNADO-EVO is a motion controller with integrated PLC functions. This multitasking CPU can manage simultaneously up to 32 axes. The controller communicates with servodrives and remote I/O through CANOPEN bus and exchanges data with other devices [operator panel, remote access device, etc.] through Ethernet network.

new features

- 10" touchscreen operator panel;
- recipe management: all settings [including phasing of knives] can be saved and retrieved for fast setup during format changes;
- machine logs access from LAN for statistic purpose;
- flexible remote access for assistance and upgrades. N° 3 [three] connection modes can be used to connect the machine: local network connected to internet, phone connection to a local internet provider, direct phone connection;
- N° 5 [five] brushless motors: FILM, JAWS, DOSER, TRANSVERSAL CUTTING KNIFE, TRANSVERSAL STRIP KNIFE;
- optional brushless motor for PRINTER head movement;
- sealing jaws electronic alternation system;
- N° 2 [two] separate motorized knives for transversal cut and perforation function. The phase of each knife can be set from the operator panel without stopping the machine;
- cooled electrical cabinet;
- improvement of PILZ safety system by utilization of magnetic safety switches on the doors and a dedicated safety module for axes speed control.

main features

- reels up to 1200 mm width [sealing width up to 600 mm] and 600 mm diameter;
- various servo-driven dosing systems available for wide range of products such as: liquids, powders, wet tissues, tablets, small solids;
- **BPMBS®**: patented modular construction system for rapid maintenance and easy sachet format change;
- standard device:
 - automatic and motorized reel unwinding;
 - automatic print registration [patent pending];
 - modem for remote troubleshooting and PLC software status diagnosis;
- basic parameters easily adjustable from control panel [sachet length, output speed, number of sachets to form a group, sealing temperatures, enabling and/or timing for various devices eg. hopper agitator, photocell control, printer, vibrator, etc.];
- various optionals available such as:
 - automatic reel centering;
 - reel join detection;
 - easy tear notch;
 - transversal and/or longitudinal perforation devices;
 - dosing system accessories;
 - end of line systems [automatic cartoning machine, manual cartoning conveyor, etc.].

liquids - semi liquids

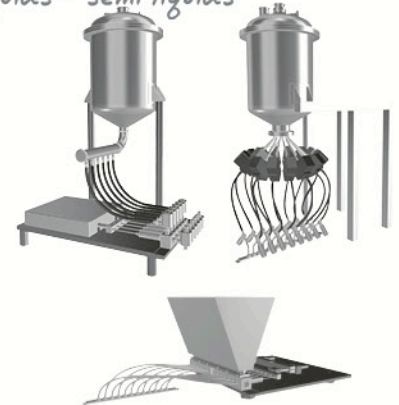

powders - solids

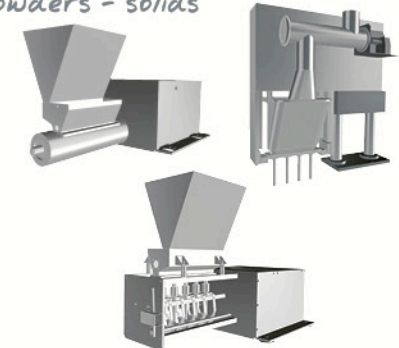

wet tissue

