

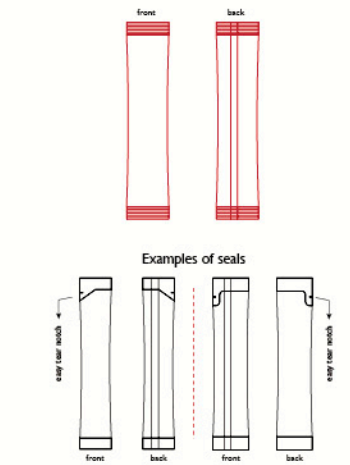

TORNADO STICK EVO *for liquids - semi liquids - powders - granules*

AUTOMATIC HIGH SPEED multiline **STICKPACK** machine for the forming and filling of **3 side seal sticks**.



technical data

max reel width	900 mm
max reel diameter	1000 mm
sachet width	min. 17 mm - max. 50 mm
max stick length	200 mm
voltage	400 V + N + PE
installed power	17 Kw
average absorption	3 - 4 Kw
air consumption	500 nl / min
dimensions	2315 x 2200 x 2400 mm

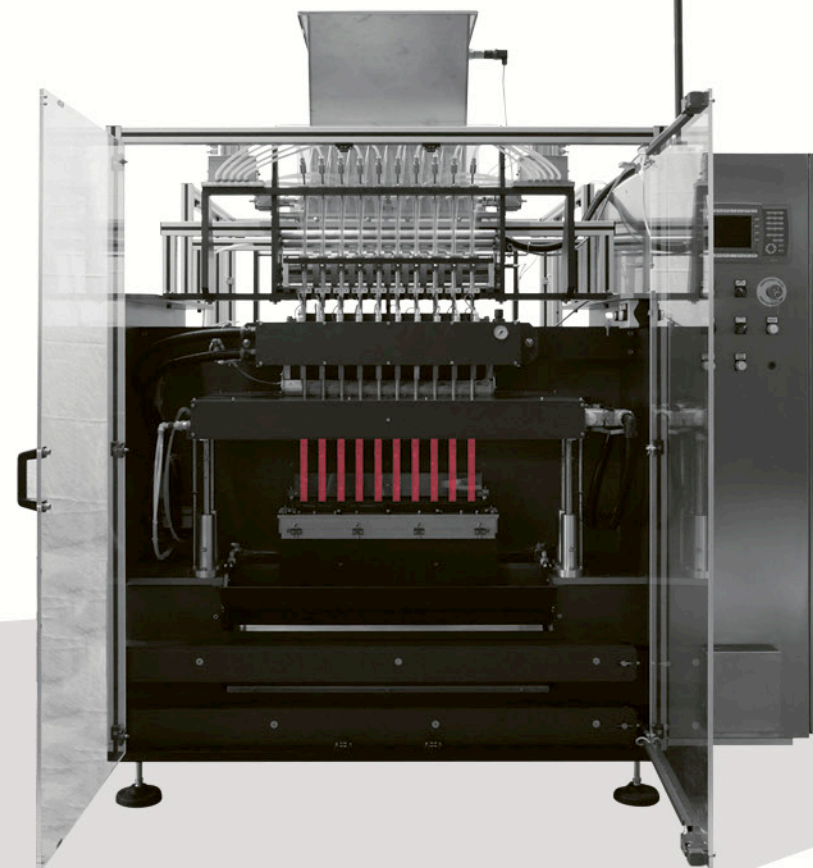
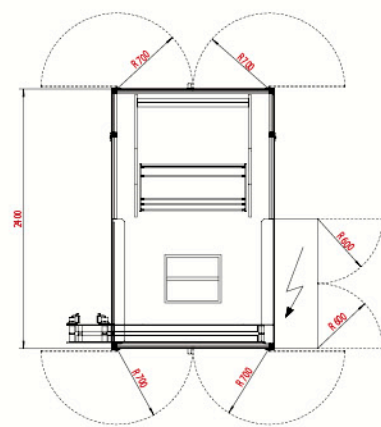
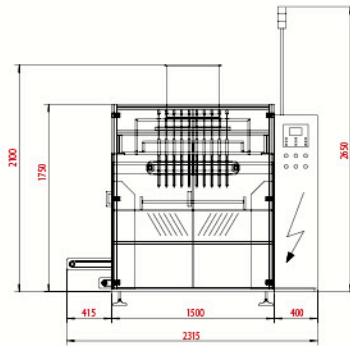
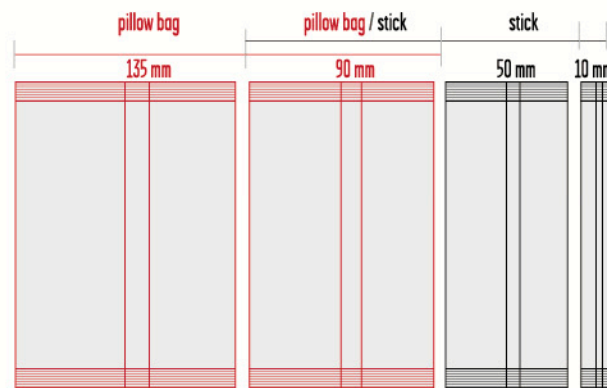

- able to handle reels of up to 900mm width and 1000mm diameter;
- machine frame in specially treated and hardened aluminium, all parts in contact with the product in AISI 316L stainless steel or foodgrade material;
- servo-driven transversal sealing jaws movement, assisted by pneumatic system;
- servo-driven reel unwinding for correct and constant control of material tension and diameter;
- constant longitudinal temperature control with individual thermocouple-thermoregulator-heater-current detector on each lane;
- double conveyor for division of full and empty sticks(while dosing unit is off);
- modem for remote troubleshooting and PLC software status diagnosis;
- basic parameters easily adjustable from control panel (output speed, sealing temperatures, enabling of various devices eg printer, agitator, photocell control, etc.);
- various optionals available such as:
 - reel join detection;
 - easy tear notch and/or bottle neck spout;
 - dosing system accessories.

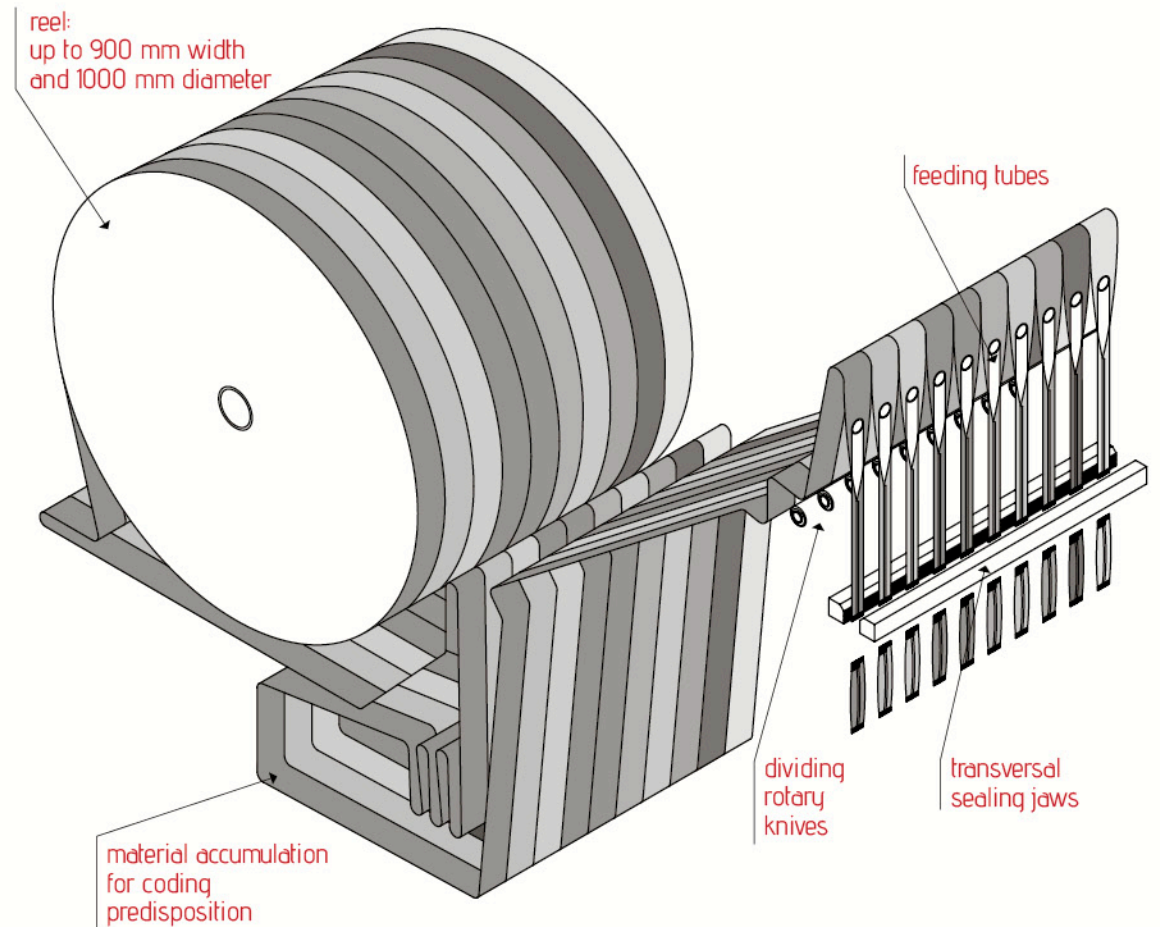
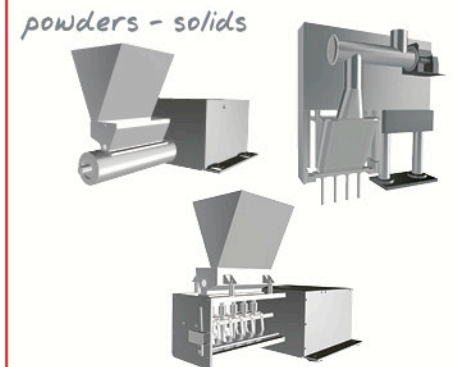

Technical documentation [DQ., IQ., OQ., PQ., FDS, RA, FAT, TM, OPP, etc...] available on request. For descriptions in other languages, please refer to our website: www.boatopack.com
 Technical data, like power and air consumption, depends on the machine + doser + optional configuration, this info will be supplied with the project quotation.

