





# Indice/Index

## Imballaggi termoformati/Thermoformed packaging

B/B2	pag. 20
C250	pag. 6
C500/1000	pag. 14
C512	pag. 10
E	pag. 12
CL1	pag. 30
CL2	pag. 32
CL3N	pag. 34
CL4	pag. 36
CL6	pag. 38
CL7	pag. 40
CL8/CLR1	pag. 42
CL10	pag. 44
CL11	pag. 46
CT	pag. 56
D	pag. 16
F/F2	pag. 18
G/G2	pag. 8
I125	pag. 52
L	pag. 50
P	pag. 54
Q500	pag. 22
Q1000	pag. 24
R	pag. 48
S/S2	pag. 26
Coperchi/Lid	pag. 28

## Imballaggi flessibili/Flexible packaging

Film stampati/Printed films	pag. 60
CP Fresh® Technology	pag. 62
Flow pack	pag. 64
Sacchetti/Bags	pag. 66

## Imballaggi accessori/Packaging accessories

Imballaggi in carta e cartone/Paper and cartonboard packaging	pag. 73
---	---------





# PRESENTAZIONE

I sistemi di confezionamento Carton Pack per il settore ortofrutticolo, rappresentano l'offerta più completa per le esigenze di mercati evoluti. Il vantaggio competitivo è rappresentato dalla rapidità di sviluppo, produzione e fornitura degli imballaggi e dalle eccellenti performance in termini di shelf-life dei prodotti alimentari. Per Carton Pack l'imballo alimentare è una scelta di stile e funzionalità. La grande competenza tecnica nell'estrusione dei film plastici (flessibili e rigidi), nella stampa flessografica, nella termoformatura e nel converting, conferiscono alla produzione un elevato livello di affidabilità e completezza a servizio del mercato alimentare internazionale.

# PRESENTATION

Carton Pack packaging systems for fruit and vegetables sector, represent the most comprehensive offer to the needs of developed markets. The competitive edge is represented by the fast development, production and supply of packagings and by its excellent performance in terms of shelf-life of food products. In Carton Pack the food packaging issue is a matter of style and functionality. The great technical expertise in the extrusion of plastic films (flexible and rigid), in flexographic printing, in thermoforming and converting, confers to the production a high level of reliability and completeness in supporting the international fruit and vegetables market.



IMBALLAGGI TERMOFORMATI  
THERMOFORMED PACKAGING



C250



Modello Model	Capacità Capacity	Dimensioni (mm) Dimension (mm)	Cassa (cm) Case (cm)	Pz./cassa Pcs./case	Pz./cartone Pcs./box	Colli/pedana Box/pallet
C250/25	125 g	145*95*25			2200	16
C250/30	125 g	145*95*30			2200	16
C250/40	200 g	145*95*40	30*40	8	2200	16
C250/42-TS	125 g	145*95*42	30*50	10	2000	16
C250/44	250 g	145*95*44	40*60	16	2200	16
C250/50	250 g	145*95*50			2200	16
C250/60	250 g	145*95*60			2200	16

Adatto a: / Suitability:



PET

Termosaldabile  
Top sealable

Stampa personalizzata  
Custom printing



OPZIONI/OPTION

Colore/Color :

Coperchio/Lid : LC250

Tappetino/Bottom Pad

Tracciabilità/Traceability

Termosaldabile/Top Sealable



G - G2

Modello Model	Capacità Capacity	Dimensioni (mm) Dimension (mm)	Cassa (cm) Case (cm)	Pz./cassa Pcs./case	Pz./cartone Pcs./box	Colli/pedana Box/pallet
G/60	250 g	116*96*60	40*60	20	2560	20
G/75	300 g	116*96*75	40*60	20	3000	20
G2/60	300 g	126*96*60	40*60	18	2820	20

Adatto a: / Suitability:

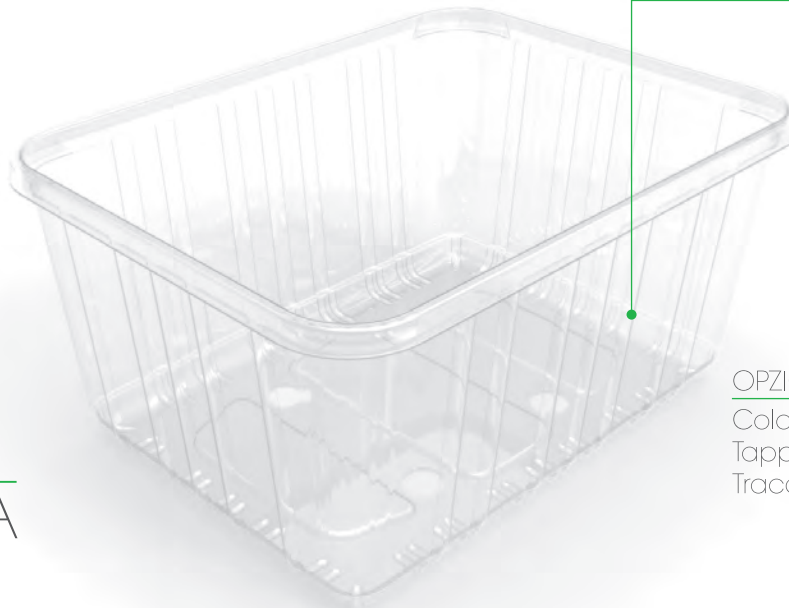

Stampa personalizzata  
Custom printing



OPZIONI/OPTION

Colore/Color :

Tappetino/Bottom Pad

Tracciabilità/Traceability

PET/PLA





C512





Modello Model	Capacità Capacity	Dimensioni (mm) Dimension (mm)	Cassa (cm) Case (cm)	Pz./cassa Pcs./case	Pz./cartone Pcs./box	Colli/pedana Box/pallet
C512/26	125 g	143*120*26	30*50/40*60	8/12	1800	20
C512/40	250 g	143*120*40	30*50/40*60	8/12	1600	20
C512/60	500 g	143*120*60	30*50/40*60	8/12	1500	20
C512/65	500 g	143*120*65	30*50/40*60	8/12	1500	20
C512/75	500 g	143*120*75	30*50/40*60	8/12	1500	20
C512/80	500 g	143*120*80	30*50/40*60	8/12	1500	20
C512/100	750 g	143*120*100	30*50/40*60	8/12	1300	20

Adatto a: / Suitability:



PET



Stampa personalizzata  
Custom printing



OPZIONI/OPTION

Colore/Color :

Coperchio/Lid : LC512

Tappetino/Bottom Pad

Manico/Handle

Tracciabilità/Traceability



E

Modello Model	Capacità Capacity	Dimensioni (mm) Dimension (mm)	Cassa (cm) Case (cm)	Pz./cassa Pcs./case	Pz./cartone Pcs./box	Colli/pedana Box/pallet
------------------	----------------------	-----------------------------------	-------------------------	------------------------	-------------------------	----------------------------

E/36	125 g	136*114*36	40*60	12	1600	20
E/50	225 g	136*114*50	40*60	12	1600	20

Adatto a: / Suitability:



PET



C500/1000



Modello Model	Capacità Capacity	Dimensioni (mm) Dimension (mm)	Cassa (cm) Case (cm)	Pz./cassa Pcs./case	Pz./cartone Pcs./box	Pz./cartone m.a.* Pcs./box a.m.*	Colli/pedana Box/pallet
------------------	----------------------	-----------------------------------	-------------------------	------------------------	-------------------------	-------------------------------------	----------------------------

C500/25	125 g	190*115*25	40*60	10	1650	1100	15
C500/41	250 g	190*115*41	40*60	10	1650	1100	15
C500/53	500 g	190*115*53	40*60	10	1650	1100	15
C500/58	500 g	190*115*58	40*60	10	1650	1100	15
C500/62	500 g	190*115*62	40*60	10	1650	1100	15
C500/68	500 g	190*115*68	40*60	10	1650	1000	15
C500/75	750 g	190*115*75	40*60	10	1650	1000	15
C500/85	750 g	190*115*85	40*60	10	1650	1000	15
C500/90	750 g	190*115*90	40*60	10	1650	1000	15
C1000/105	1000 g	190*115*105	40*60	10	920	920	15

\*Macchine automatiche  
\* Automatic machine

Adatto a: / Suitability:



Stampa personalizzata  
Custom printing

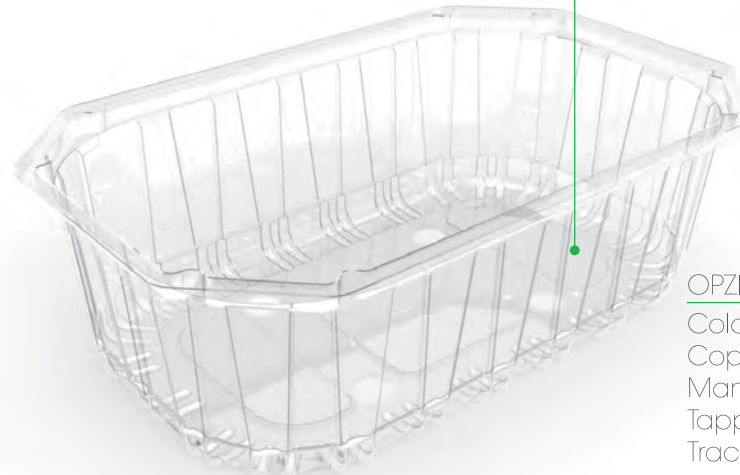

OPZIONI/OPTION

Colore/Color :

Coperchio/Lid : LC500

Manico/Handle

Tappetino/Bottom Pad

Tracciabilità/Traceability

PET/PLA



D

Modello Model	Capacità Capacity	Dimensioni (mm) Dimension (mm)	Cassa (cm) Case (cm)	Pz./cassa Pcs./case	Pz./cartone Pcs./box	Colli/pedana Box/pallet
D/50	500 g	186*117*50	40*60	10	1200	15
D/85	500 g	186*117*85	40*60	10	1160	15

Adatto a: / Suitability:



Termosaldabile  
Top sealable

Stampa personalizzata  
Custom printing

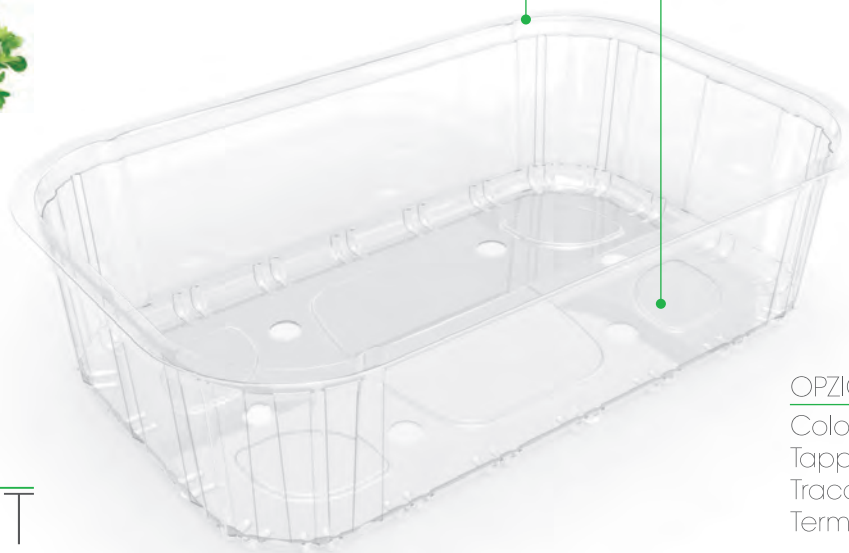

OPZIONI/OPTION

Colore/Color :

Tappetino/Bottom Pad

Tracciabilità/Traceability

Termosaldabile/Top Sealable

PET



F - F2



Modello Model	Capacità Capacity	Dimensioni (mm) Dimension (mm)	Cassa (cm) Case (cm)	Pz./cassa Pcs./case	Pz./cartone Pcs./box	Colli/pedana Box/pallet
F/85	750 g	172*132*85	30*50	6	768	16
F2/95	1000 g	170*139*95	30*50	6	864	18

Adatto a: / Suitability:

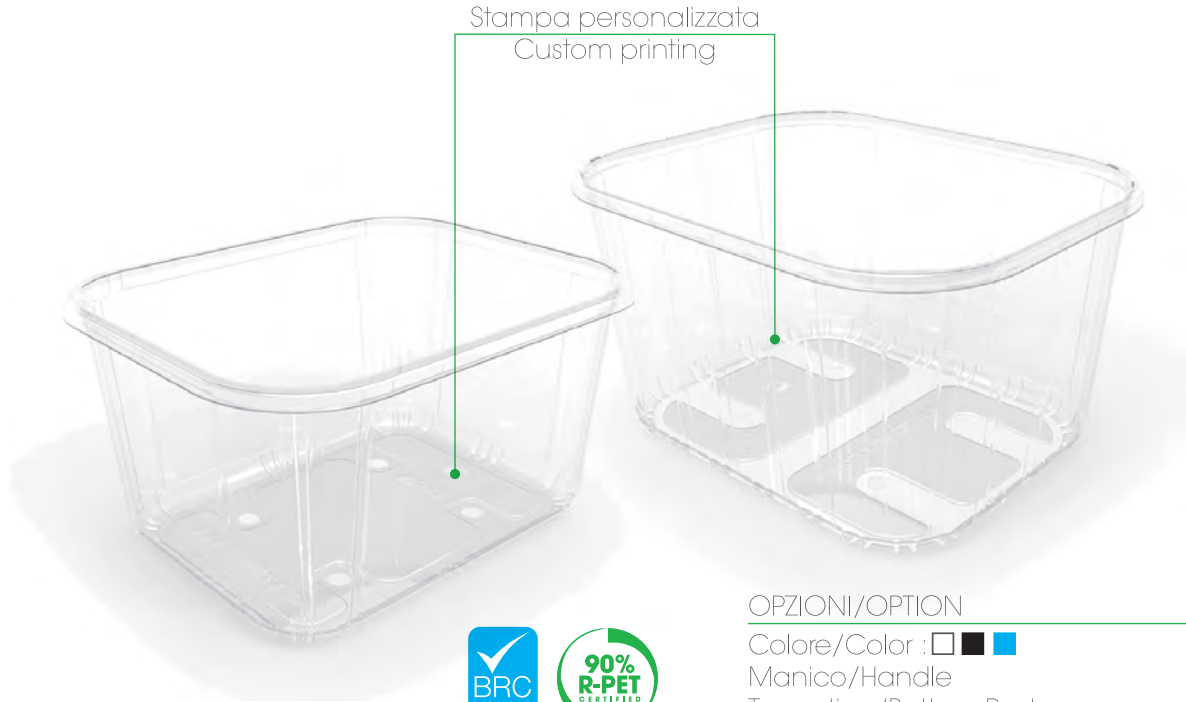

OPZIONI/OPTION

Colore/Color :

Manico/Handle

Tappetino/Bottom Pad

Tracciabilità/Traceability

PET/PP



B - B2



Modello Model	Capacità Capacity	Dimensioni (mm) Dimension (mm)	Cassa (cm) Case (cm)	Pz. /cassa Pcs. /case	Pz./cartone Pcs./box	Colli/pedana Box/pallet
------------------	----------------------	-----------------------------------	-------------------------	--------------------------	-------------------------	----------------------------

B/58	500 g	186*115*58	40*60	10	1100	16
B/60	500 g	186*115*60	40*60	10	1100	16
B/75	750 g	186*115*75	40*60	10	1050	16
B/85	750 g	186*115*85	40*60	10	1050	16
B/93	1000 g	186*115*93	40*60	10	1100	16
B/95	1000 g	186*115*95	40*60	10	1100	16
B/105	1000 g	186*115*105	40*60	10	1100	16
B/110	1000 g	186*115*110	40*60	10	1100	16
B2/53	500 g	193*119*53	40*60	10	1080	16
B2/58	500 g	193*119*58	40*60	10	1000	16
B2/60	500 g	193*119*60	40*60	10	1000	16
B2/105	1000 g	193*119*105	40*60	10	900	16
B2/110	1000 g	193*119*110	40*60	10	900	16

Adatto a: / Suitability:



PET/PP

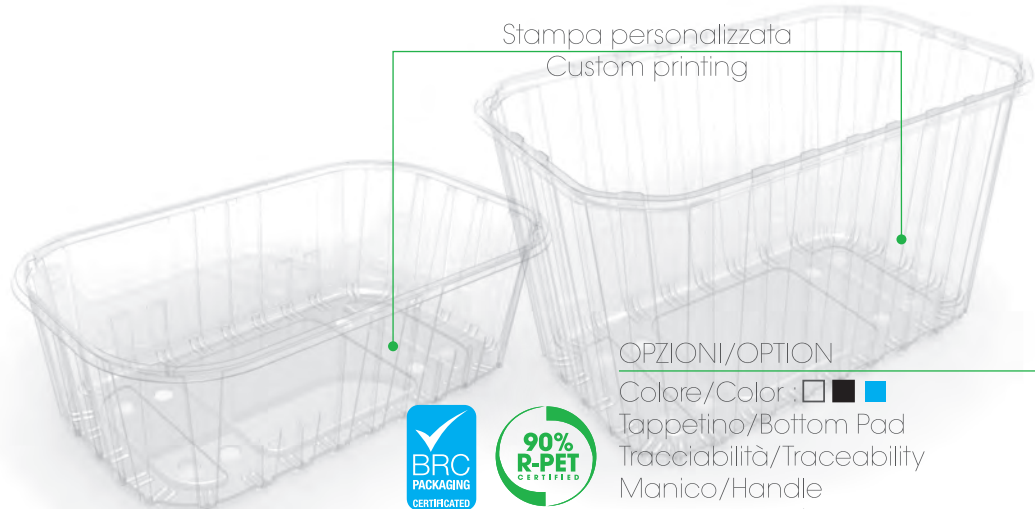

Stampa personalizzata  
Custom printing

OPZIONI/OPTION

Colore/Color:

Tappetino/Bottom Pad

Tracciabilità/Traceability

Manico/Handle

Coperchio/Lid: Sì, modello B / Yes, model B





Q

Modello Model	Capacità Capacity	Dimensioni (mm) Dimension (mm)	Cassa (cm) Case (cm)	Pz./cassa Pcs./case	Pz./cartone Pcs./box	Colli/pedana Box/pallet
Q500/30	300 g	182*182*30	40*60	6	780	16
Q500/40	500 g	182*182*40	40*60	6	780	16
Q500/45	500 g	182*182*45	40*60	6	780	16
Q45/3C	500 g	182*182*45	40*60	6	780	16
QN/45	500 g	182*182*45	40*60	6	672	16
Q1000/60	750 g	182*182*60	40*60	6	780	16
Q1000/70	1000 g	182*182*70	40*60	6	780	16
Q1000/75	1000 g	182*182*75	40*60	6	780	16
Q1000/100	1000 g	182*182*100	40*60	6	650	16
Q1500/120	1500 g	182*182*120	40*60	6	650	16

Adatto a: / Suitability:



OPZIONI/OPTION

Colore/Color :

Coperchio/Lid : LQ

Tappetino/Bottom Pad

Tracciabilità/Traceability

Termosaldabile/Top Sealable

PET





Q1000/A

Modello Model	Capacità Capacity	Dimensioni (mm) Dimension (mm)	Cassa (cm) Case (cm)	Pz./cassa Pcs./case	Pz./cartone Pcs./box	Colli/pedana Box/pallet
Q1000/40A-85	4 - (ø85)	182*182*40	40*60	6	780	16
Q1000/50A-90	4 - (ø90)	182*182*50	40*60	6	780	16
Q1000/50A-75	4 - (ø75)	182*182*50	40*60	6	780	16

Adatto a: / Suitability:



OPZIONI/OPTION

Colore/Color :

Coperchio/Lid : LQ/A

PET



S - S2





Modello Model	Capacità Capacity	Dimensioni (mm) Dimension (mm)	Cassa (cm) Case (cm)	Pz./cassa Pcs./case	Pz./cartone Pcs./box	Colli/pedana Box/pallet
S/25	500 g	240*77*25	40*60	16	1200	18
S/35	500 g	240*77*35	40*60	16	1200	18
S2/25	500 g	284*77*25	40*60	16	1056	20
S2/35	500 g	284*77*35	40*60	16	960	20

Adatto a: / Suitability:

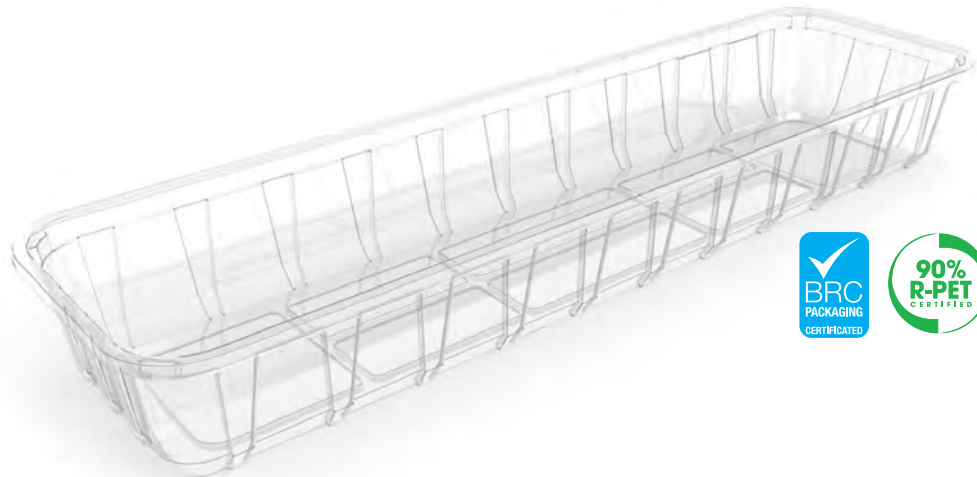

OPZIONI/OPTION

Colore/Color :

PET

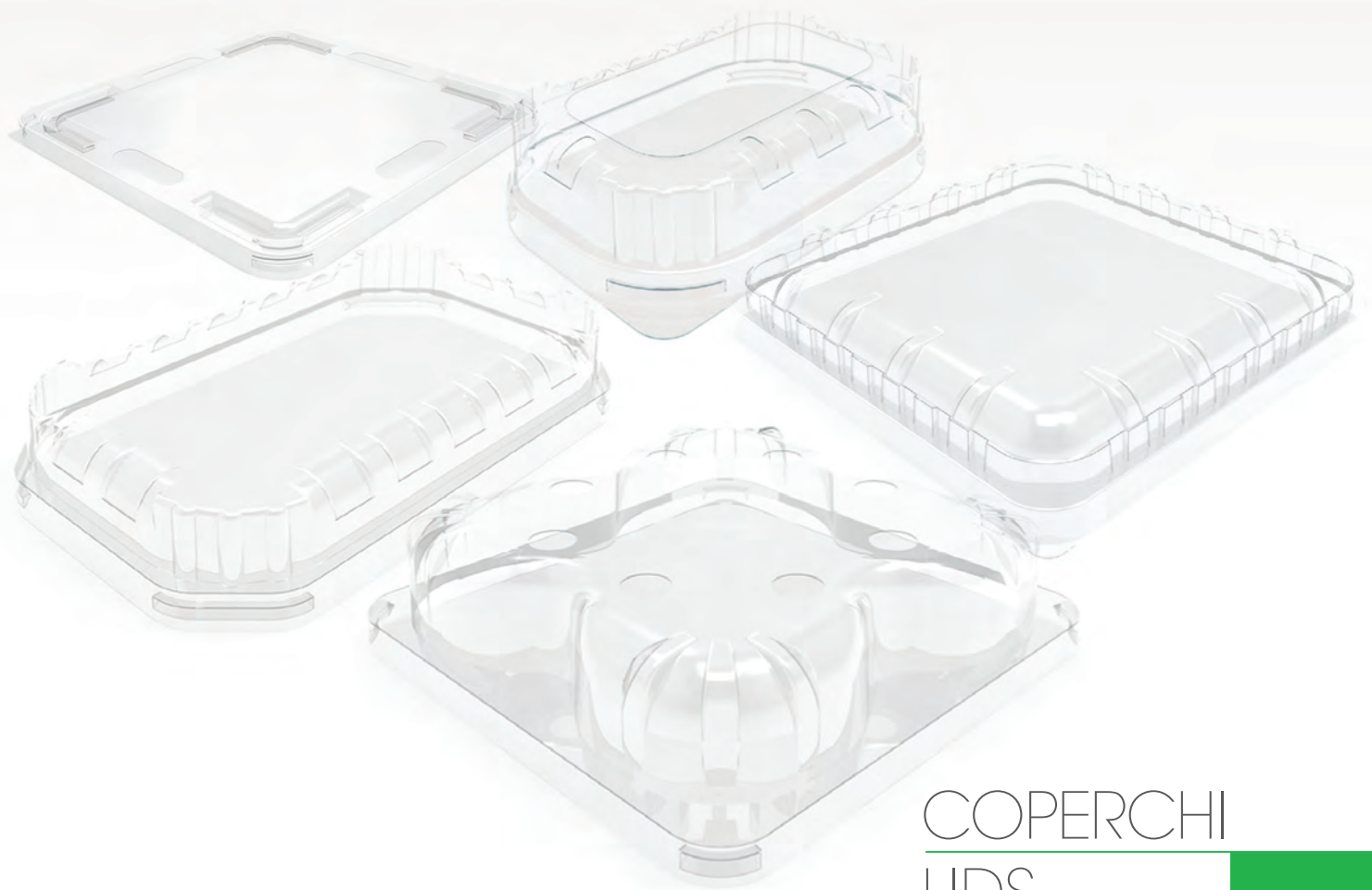

COPERCHI  
LIDS

Modello Model	Adatto a Suitability	Dimensioni (mm) Dimension (mm)	Pz./cartone Pcs./box	Colli/pedana Box/pallet
------------------	-------------------------	-----------------------------------	-------------------------	----------------------------

LC250/P	C250-TS	146*97*12 (0*)	1290	16
LC250/25	C250	146*97*25 (13*)	1100	16
LC250/31	C250	146*97*31 (19*)	1100	16
LC250/35	C250	146*97*35 (23*)	1100	16
LC500/25	B/C500/C1000	193*118*25 (13*)	550	20
LC500/32	B/C500/C1000	193*118*32 (20*)	550	20
LC500/35	B/C500/C1000	193*118*35 (23*)	550	20
LC500/42	B/C500/C1000	193*118*42 (30*)	550	20
LC512/17	C512	146*123*17 (5*)	750	24
LQ26	Q-QN	186*186*26 (14*)	780	12
LQ32	Q-QN	186*186*32 (20*)	390	16
LQ35/A	Q-Q/A	186*186*35 (23*)	390	16
LQ45/A	Q-Q/A	186*186*45 (33*)	390	16
LQ/P	Q-QN	186*186*12 (0*)	672	12
LE/P	E	139*117*12 (0*)	750	24

\* Altezza netta / Net height

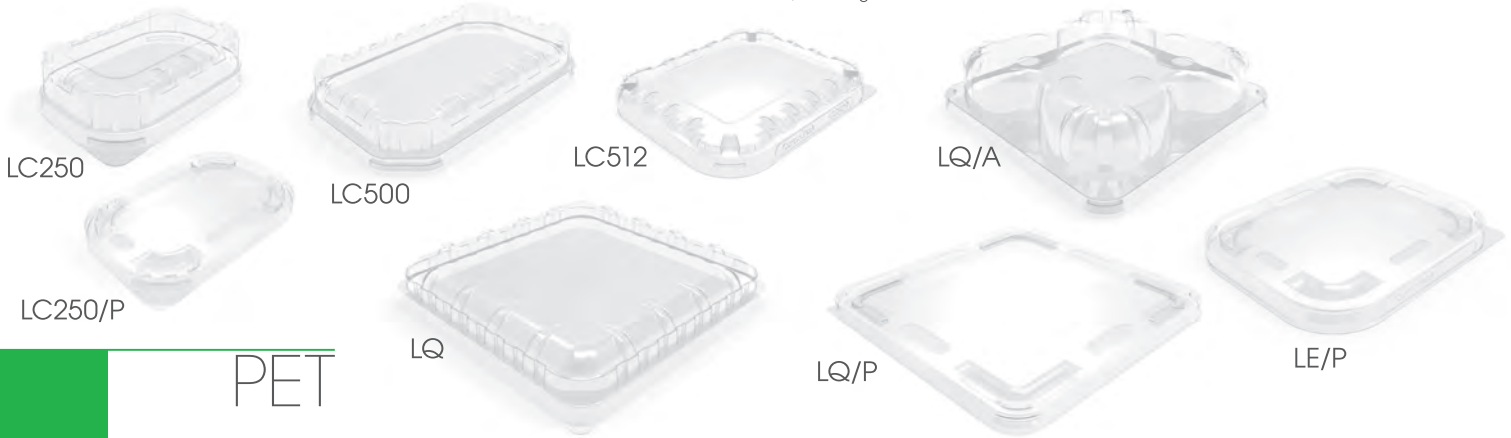

PET



CL1

Modello Model	Capacità Capacity	Dimensioni (mm) Dimension (mm)	Cassa (cm) Case (cm)	Pz./cassa Pcs./case	Pz./cartone Pcs./box	Colli/pedana Box/pallet
CL1/53	300 g	189*119*53	40*60	10	600	20
CL1/60	300 g	189*119*60	40*60	10	600	20
CL1/70-2C	500 g	189*119*70	40*60	10	450	20
CL1/70-3C	500 g	189*119*70	40*60	10	400	20
CL1/75	500 g	189*119*75	40*60	10	600	20
CL1/80N	500 g	189*119*80	40*60	10	600	20
CL1/85N	500 g	189*119*85	40*60	10	600	20
CL1/90	500 g	189*119*90	40*60	10	600	20
CL1/100	750 g	189*119*100	40*60	10	500	20
CL1/110	750 g	189*119*110	40*60	10	500	20
CL1/135	1000 g	189*119*135	40*60	10	500	20

Adatto a: / Suitability:

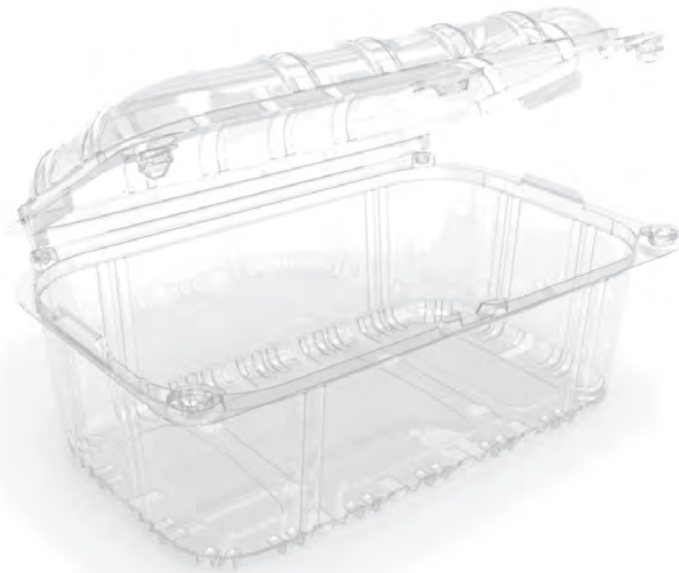

PET





CL2

Modello Model	Capacità Capacity	Dimensioni (mm) Dimension (mm)	Cassa (cm) Case (cm)	Pz./cassa Pcs./case	Pz./cartone Pcs./box	Colli/pedana Box/pallet
CL2/40	125 g	128*96*40	40*60	18	1250	16
CL2/55	200 g	128*96*55	40*60	18	1250	16
CL2/75	250 g	128*96*75	40*60	18	1250	16
CL2/78	250 g	128*96*78	40*60	18	1250	16

Adatto a: / Suitability:



PET



CL3N



Modello Model	Capacità Capacity	Dimensioni (mm) Dimension (mm)	Cassa (cm) Case (cm)	Pz./cassa Pcs./case	Pz./cartone Pcs./box	Colli/pedana Box/pallet
CL3N/56	250 g	180*117*56	40*60	12	580	20
CL3N/64	250 g	180*117*64	40*60	12	580	20

Adatto a: / Suitability:



PET



CL4

Modello Model	Capacità Capacity	Dimensioni (mm) Dimension (mm)	Cassa (cm) Case (cm)	Pz./cassa Pcs./case	Pz./cartone Pcs./box	Colli/pedana Box/pallet
------------------	----------------------	-----------------------------------	-------------------------	------------------------	-------------------------	----------------------------

CL4/130	2000 g	280*184*130	40*60	4	250	16
---------	--------	-------------	-------	---	-----	----

Adatto a: / Suitability:

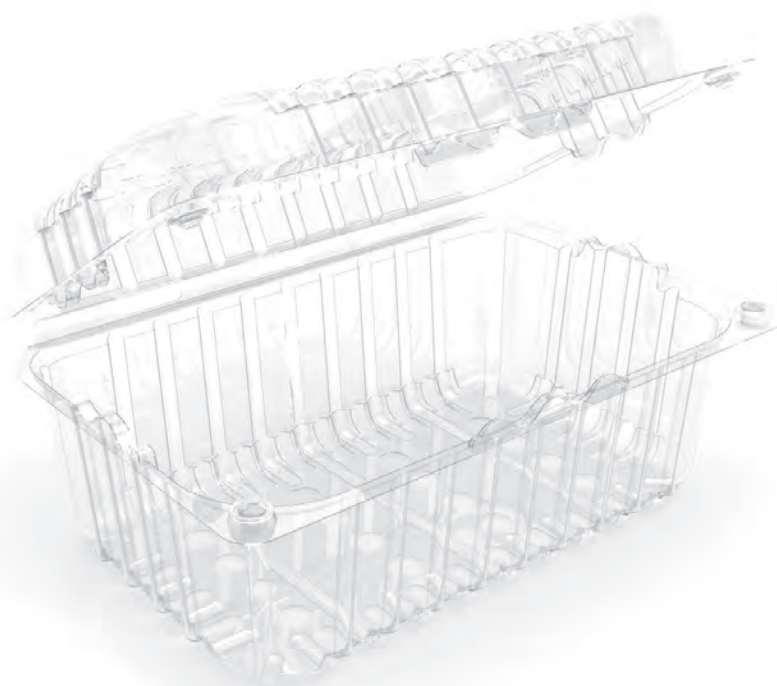

PET



CL6

Modello Model	Capacità Capacity	Dimensioni (mm) Dimension (mm)	Cassa (cm) Case (cm)	Pz./cassa Pcs./case	Pz./cartone Pcs./box	Colli/pedana Box/pallet
CL6/49	500 g	186*184*49	40*60	6	450	16
CL6/54	500 g	186*184*54	40*60	6	450	16
CL6/65	500 g	186*184*65	40*60	6	450	16
CL6/75	750 g	186*184*75	40*60	6	450	16
CL6/94	1000 g	186*184*94	40*60	6	390	16
CL6/110	1000 g	186*184*110	40*60	6	350	16
CL6/130	1500 g	186*184*130	40*60	6	350	16

Adatto a: / Suitability:



PET





CL7

Modello Model	Capacità Capacity	Dimensioni (mm) Dimension (mm)	Cassa (cm) Case (cm)	Pz./cassa Pcs./case	Pz./cartone Pcs./box	Colli/pedana Box/pallet
CL7/75	500 g	188*143*75	40*60	8	420	16
CL7/85	750 g	188*143*85	40*60	8	400	16
CL7/105	750 g	188*143*105	40*60	8	420	16
CL7/125	1000 g	188*143*125	40*60	8	400	16
CL7/135	1000 g	188*143*135	40*60	8	400	16

Adatto a: / Suitability:



PET



CL8/CLR1



Modello Model	Capacità Capacity	Dimensioni (mm) Dimension (mm)	Cassa (cm) Case (cm)	Pz./cassa Pcs./case	Pz./cartone Pcs./box	Colli/pedana Box/pallet
------------------	----------------------	-----------------------------------	-------------------------	------------------------	-------------------------	----------------------------

CLR1/130	500 g	205*125*130	40*60	10	405	20
CL8/136	1000 g	190*146*136	40*60	8	600	20

Adatto a: / Suitability:



PET



CL10



Modello Model	Capacità Capacity	Dimensioni (mm) Dimension (mm)	Cassa (cm) Case (cm)	Pz./cassa Pcs./case	Pz./cartone Pcs./box	Colli/pedana Box/pallet
------------------	----------------------	-----------------------------------	-------------------------	------------------------	-------------------------	----------------------------

CL10/70	500 g	284*77*70	40*60	10	594	20
---------	-------	-----------	-------	----	-----	----

Adatto a: / Suitability:

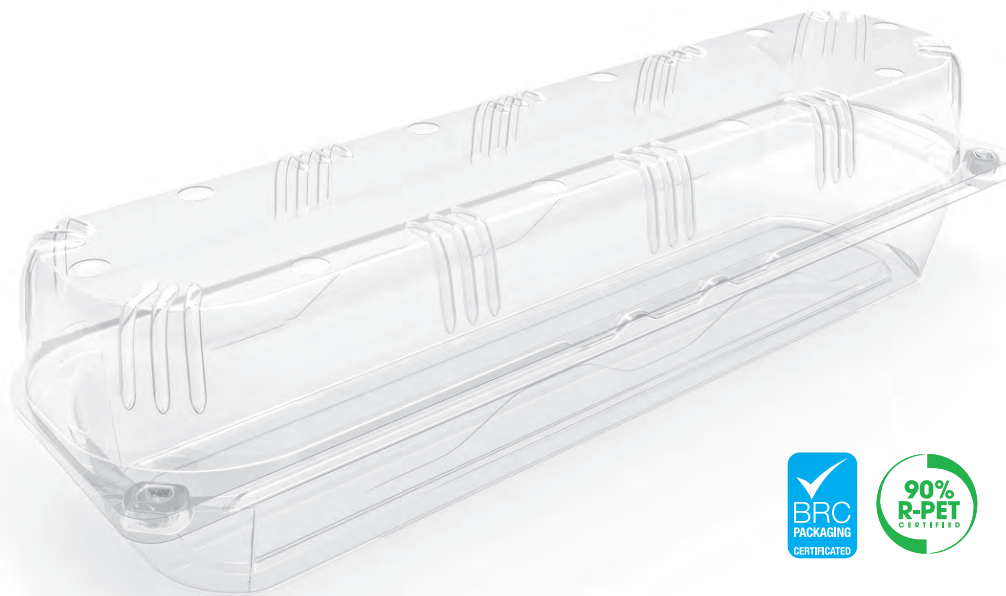

PET

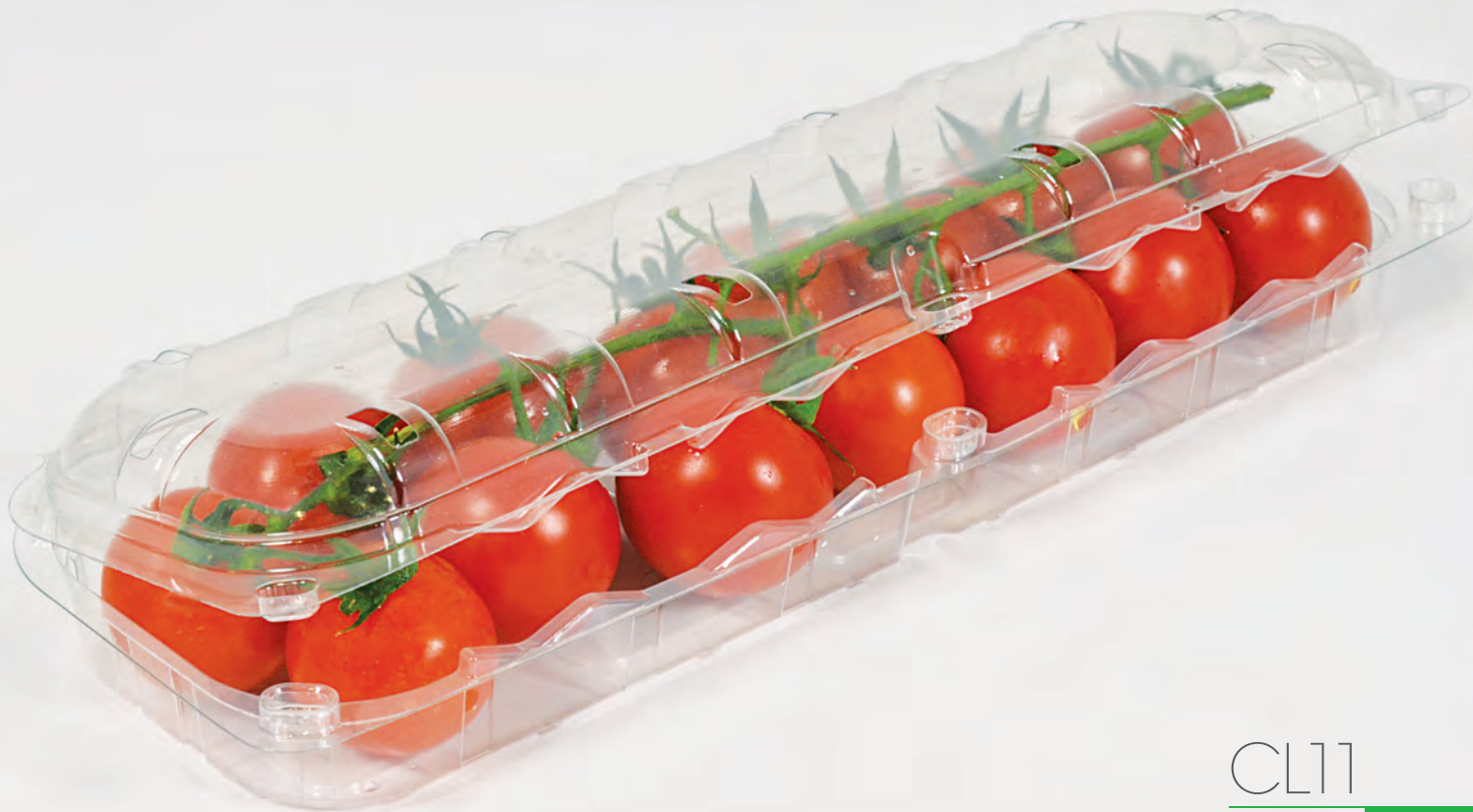

CL11

Modello Model	Capacità Capacity	Dimensioni (mm) Dimension (mm)	Cassa (cm) Case (cm)	Pz./cassa Pcs./case	Pz./cartone Pcs./box	Colli/pedana Box/pallet
CL11/44	500 g	286*95*44	40*60	8	504	16
CL11/85	1000 g	286*95*85	40*60	8	480	16

Adatto a: / Suitability:

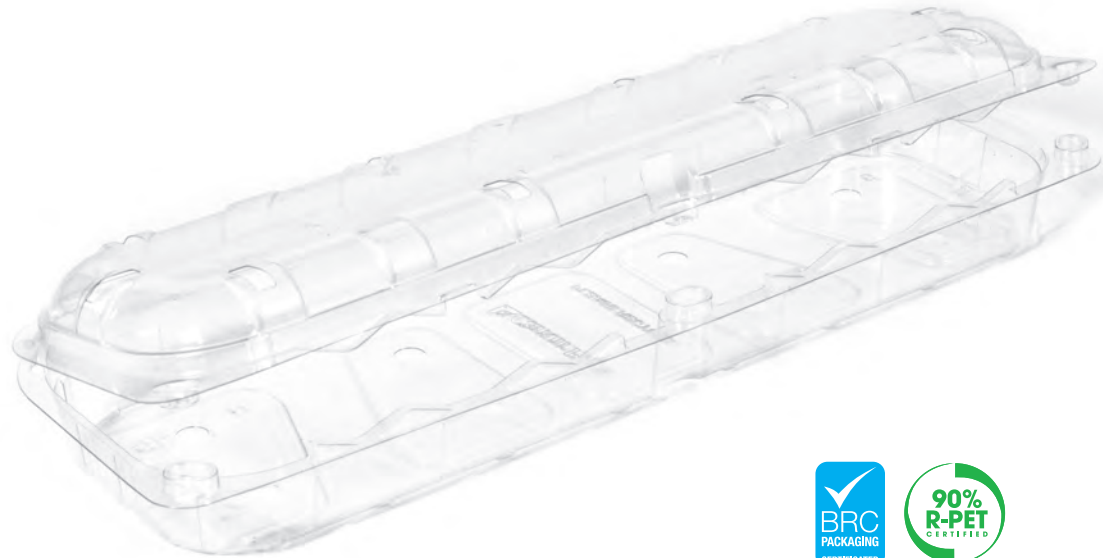

PET



R

Modello Model	Capacità Capacity	Dimensioni (mm) Dimension (mm)	Cassa (cm) Case (cm)	Pz./cassa Pcs./case	Pz./cartone Pcs./box	Colli/pedana Box/pallet
------------------	----------------------	-----------------------------------	-------------------------	------------------------	-------------------------	----------------------------

R/20	250 g	180*130*20	40*60	9	1400	24
R/25	250 g	180*130*25	40*60	9	1400	24
R/30	300 g	180*130*30	40*60	9	950	24
R/35	350 g	180*130*35	40*60	9	950	24
R/40	400 g	180*130*40	40*60	9	950	24
R/50	500 g	180*130*50	40*60	9	950	24

Adatto a: / Suitability:



OPZIONI/OPTION

Colore/Color :

PET





L

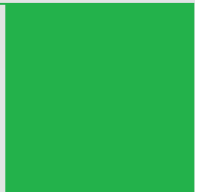

Modello Model	Capacità Capacity	Dimensioni (mm) Dimension (mm)	Cassa (cm) Case (cm)	Pz./cassa Pcs./case	Pz./cartone Pcs./box	Colli/pedana Box/pallet
L60	150 g	185*143*60	40*60	8	504	20
L80	250 g	185*143*80	40*60	8	480	20
L85	250 g	185*143*85	40*60	8	480	20
L125	500 g	185*143*125	40*60	8	450	20

Adatto a: / Suitability:



OPZIONI/OPTION

Colore/Color :

PP/PET



1125



Modello Model	Capacità Capacity	Dimensioni (mm) Dimension (mm)	Cassa (cm) Case (cm)	Pz./cassa Pcs./case	Pz./cartone Pcs./box	Colli/pedana Box/pallet
I125/45	150 g	195*150*45	40*60	8	594	20
I125/60	150 g	195*150*60	40*60	8	594	20
I125/70	200 g	195*150*70	40*60	8	540	20
I125/80	200 g	195*150*80	40*60	8	540	20

Adatto a: / Suitability:



OPZIONI/OPTION

Colore/Color :

PET





P



Modello Model	Capacità Capacity	Dimensioni (mm) Dimension (mm)	Cassa (cm) Case (cm)	Pz./cassa Pcs./case	Pz./cartone Pcs./box	Colli/pedana Box/pallet
P/25	250 g	245*145*25	40*60	6	600	16
P/40	400 g	245*145*40	40*60	6	560	16
P/50	500 g	245*145*50	40*60	6	540~560	16~18
P/60	700 g	245*145*60	40*60	6	576	16
P/60 3C	500 g	245*145*60	40*60	6	512~540	18
P/65	1000 g	245*145*65	40*60	6	512~540	16~18
P/80	1000 g	245*145*80	40*60	6	600	18
P/105	1500 g	245*145*105	40*60	6	540	18
P/125	1500 g	245*145*125	40*60	6	540	18

Adatto a: / Suitability:



OPZIONI/OPTION

Colore/Color :

PP/PET



CT

Modello Model	Capacità Capacity	Dimensioni (mm) Dimension (mm)	Cassa (cm) Case (cm)	Pz./cassa Pcs./case	Pz./cartone Pcs./box	Colli/pedana Box/pallet
CT/48	900 cc	(∅) 187*48 (h)	40*60	6	396	16
CT/60	1172 cc	(∅) 187*60 (h)	40*60	6	378	16
CT/87	1593 cc	(∅) 187*87 (h)	40*60	6	360	16

Adatto a: / Suitability:



OPZIONI/OPTION

Colore/Color :

PET









Ortomio

Cuori di Iceberg

PRONTA DA CONDIRE

PRODOTTO LAVATO E PRONTO PER IL CONSUMO

Natura Chiama

SELEX

Mista Saporita

PRODOTTO LAVATO E PRONTO PER IL CONSUMO

FILIERA CONTROLLATA

foglia verde

le Croccante insalata mista  
span di zucchero, radicchio, indivia

pronta da condire

- prodotto fresco già lavato
- coltivato in Italia



FILM STAMPATI  
PRINTED FILM

## STRUTTURA/STRUCTURE

Film monostrato o accoppiato / Monolayer or laminated films

## MATERIALE/MATERIAL

Polipropilene, Polietilene, PET, PLA, Carta / Polypropylene, Polyethylene, PET, PLA, Paper

## ADATTO A/SUITABILITY

Confezionamento verticale/orizzontale, Chiusura con film saldante, IV Gamma, I Gamma  
Vertical/horizontal packaging, Top sealing, Fresh cut produce, Fruit & Vegetables

## SPECIFICHE/FEATURES

Elevata brillantezza, ottima macchinabilità, efficace effetto antifog, estensione shelf-life  
High gloss, excellent machinability, effective antifog effect, shelf-life extension



## OPZIONI/OPTION

Microforabile · Macroforabile · Film barriera (EVOH, PET Saran) · Anti-Fog (Laccato/In massa) · Pelabile · Mattabile (Laccato/In massa)  
Micro perforation · Macro perforation · Barrier Film (EVOH, PET Saran) · Anti-Fog (Varnish/Mass) · Peelable · Matted (Varnish/Mass)



CP fresh®



CON CP FRESH®  
WITH CP FRESH®



SENZA  
CP FRESH®  
WITHOUT  
CP FRESH®

TECNOLOGIA CP FRESH®  
CP FRESH® TECHNOLOGY



## GARANZIA DI FRESCHEZZA/FRESHNESS GUARANTEE

CP FRESH® é espressione di una competenza tecnica Carton Pack che sfrutta differenti tecnologie sinergiche per conseguire un unico obiettivo finale: l'**estensione della shelf-life** in relazione a specifici prodotti alimentari con specifiche esigenze di conservazione.

La tecnologia CP FRESH® inoltre permette di **auto-bilanciare la naturale "respirazione" del prodotto confezionato**, allo scopo di mantenere le qualità organolettiche e la freschezza fino al consumo **mantenendo invariato il sapore originario del prodotto**.

CP FRESH® is the expression of Carton Pack technical expertise that uses different synergic technologies to achieve the ultimate goal: the **extension of shelf life** of specific foods with specific conservation requirements.

Furthermore, CP FRESH® technology allows to **auto-balance the natural "breathing" of the packaged product**, in order to maintain the organoleptic quality and freshness until consumption while **keeping unchanged the original flavour of the product**.

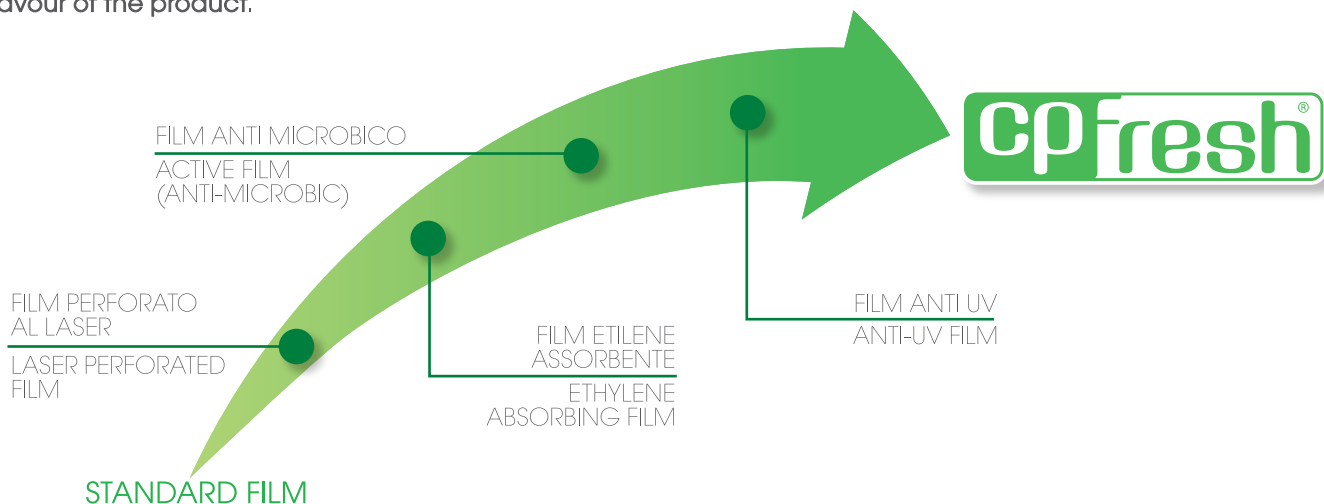





FRESHISSIMI  
FELLINI PATRIZIO  
GUARDAMI  
PRENDIMI  
GUSTAMI  
da LAVARE  
PRODOTTO ITALIANO

FRESHISSIMI  
FELLINI PATRIZIO  
GUARDAMI  
PRENDIMI  
GUSTAMI  
PRODOTTO ITALIANO

FRESHISSIMI  
FELLINI PATRIZIO  
GUARDAMI  
PRENDIMI  
GUSTAMI  
PRODOTTO ITALIANO

*Gli Aromi  
di Armando*

FLOW PACK



## MATERIALE/MATERIAL

Polipropilene, Polietilene, PLA, Carta / Polypropylene, Polyethylene, PLA, Paper

## ADATTO A/SUITABILITY

Confezionamento flow pack orizzontale / Horizontal flow pack packaging

## SPECIFICHE/FEATURES

- Microperforazione a banda piena (continua o a registro)  
Full band microperforation (in continuous or by registration marks)
- Macroperforazione a banda piena (continua o a zona, diametro fori 2 ~ 8 mm)  
Full band macroperforation (in continuous or by area, holes diameter 2 ~ 8 mm)
- Trattamento anti-fog e tecnologia CP Fresh® / Anti-fog system and CP Fresh® Technology
- Film a doppio strato finestrato (PP/PE + carta) / Windowed double layer film (PP/PE + paper)
- Eccezionale performance meccanica / Outstanding mechanical performance
- Eccezionali proprietà ottiche / Outstanding optical properties
- Eccezionale resistenza nella saldatura / Outstanding welding strenght





SACCHETTI  
BAGS

Tra le soluzioni per l'imballaggio di ortofrutta offerte da Carton Pack, la gamma dei sacchetti in film flessibile costituisce sicuramente un elemento cardine. Molti sono i vantaggi connessi all'utilizzo di questo tipo di imballaggio: l'abbattimento dei costi connessi agli "scarti operati dal consumatore"; la porzionatura, definendo a priori l'unità d'acquisto; la specifica resistenza ad acqua e umidità (mantiene la freschezza interna e isola dagli agenti esterni durante le operazioni di trasporto e distribuzione); la possibilità di comunicare e valorizzare il marchio ed eventuali certificazioni di prodotto. Il Dipartimento di Design Industriale Carton Pack, è in grado di offrire un supporto completo nella realizzazione di sacchetti personalizzati dalla fase di studio del concept, all'ingegnerizzazione, all'elaborazione della grafica personalizzata.

#### SACCHETTI LAMINATI IN PP/PE/CARTA:

SACCHETTI IN BOBINA "A STRAPPO"  
SACCHETTI CONICI  
SACCHETTI AUTOPORTANTI CON CHIUSURA ZIP  
SACCHETTI FINESTRATI CON CARTA  
SACCHETTI MAZZETTATI  
SACCHETTI CON PRETAGLI E FUSTELLATURE PERSONALIZZATE



Among the solutions for the packaging of fruit and vegetables offered by Carton Pack, the range of bags made in flexible film it's certainly a key element. There are many advantages using this type of packaging: the reduction of costs related to "waste operated by the consumer"; portioning, setting out in advance the purchase unit; the specific resistance to water and moisture (keep freshness inside and isolates it from external agents during transport operations and distribution); the ability to communicate and enhance the brand and any product certification. The Department of Industrial Design in Carton Pack, is able to offer full support in making custom bags starting from the study of the concept, to engineering, to the development of custom graphics.

#### BAGS PP/PE/PAPER LAMINATED:

BAGS ON ROLLS WITH PRECUT SYSTEM  
CONICAL BAGS  
STAND UP BAGS WITH ZIP LOCK SYSTEM  
WINDOWED BAGS LAMINATED WITH PAPER  
BAGS ON WICKETS  
PRECUT BAGS WITH CUSTOM PUNCHING











Carton Pack progetta, produce e distribuisce una vastissima gamma di prodotti accessori per l'imballaggio dell'ortofrutta. L'elevato grado di personalizzazione, la varietà e l'alta qualità dei materiali utilizzati sono elementi distintivi dei prodotti Carton Pack nel mercato internazionale.

- Bande per reti in plastica monofilm e accoppiate, stampate (fino a 10 colori) adatte per macchine confezionatrici automatiche
- Reti plastiche estruse e tessute di vari colori (per confezionamento automatico)
- Etichette e fascie adesive o termosaldate, personalizzate per varie applicazioni
- Coccoarde e talloncini in cartoncino plastificato o materiale plastico
- Pergamini in carta velina lisciata stampata, velina monolucida, alluminio, carta cristallizzata o porcellanata
- Contenitori alveolari in PET, polipropilene e polpa di legno
- Copertine di vari formati in cartone, polietilene e polipropilene per l'applicazione su cassetta in plastica o legno, plateau o padella
- Nastri e bande decorative in plastica stampata e metallizzata
- Casette personalizzate in legno o masonite
- Angolari in cartone e plastica

---

Carton Pack designs, manufactures and distributes a wide range of accessory products for fruits and vegetables packaging. The high level of customization, the variety and the high quality of the raw materials used, are distinctive features for Carton Pack products in the international markets.

- Bands for nets made in plastic film, mono or double-layered, printed (up to 10 colors) and suitable for automatic packaging machines
- Plastic nets, extruded and woven in different colors (for automatic packaging)
- Extruded and knitted nets in different colours for automatic packaging
- Tags and tabs made in plasticized cardboard or plastic rigid film
- Glassine printed tissue paper, sulphite tissue paper, aluminum, crystallized or porcelainized tissue paper
- Alveolar containers in PET, polypropylene and wooden pulp
- Covers in cartonboard, polyethylene and polypropylene of various formats, suitable for cassettes made of plastic or wood, plateaux or plates
- Ribbons and decorative bands of printed and metallized plastic
- Customized cases made in wood or masonite
- Plastic and carton edgeboards











La linea prodotti in carta e cartone rappresenta uno dei punti di forza della produzione Carton Pack che vanta una decennale esperienza nella produzione di questa tipologia di soluzioni per il confezionamento. L'imballaggio in carta/cartone si presta facilmente alla valorizzazione del brand e del prodotto ortofruitticolo grazie alla possibilità di realizzare stampe anche complesse con soluzioni cartotecniche evolute e progettate per le specifiche esigenze del mercato.

Il Dipartimento di Design Industriale Carton Pack, è in grado di offrire un supporto completo nella realizzazione di imballaggi in carta o cartone dalla fase di studio del concept, all'ingegnerizzazione dell'imballo, all'elaborazione della grafica personalizzata.

PRODOTTI IN CARTA:	PRODOTTI IN CARTONCINO E CARTONE MICRO-ONDULATO:	PRODOTTI IN CARTONE ONDULATO:
BORSE, SHOPPER BUSTE e SACCHETTI PERGAMINI e VELINE FONDI ETICHETTE ADESIVE COCCARDE/TALLONCINI.	CESTINI (con/senza manico) VASSOI SCATOLE CONTENITORI FUSTELLATI BANDE DECORATIVE	PLATEAUX PADELLE SCATOLE/BOX ESPOSITORI CONTENITORI FUSTELLATI

The paper and cardboard products line is one of the strengths of Carton Pack production, thanks to a 50 years expertise in the production of this kind of packaging solutions. The paper/cardboard packaging easily contributes to the empowerment of the brand identity and the fruit and vegetable product's appeal; this is due to the possibility of printing even complex graphics with high level papermaking solutions designed for the specific needs of the market. The Industrial Design Dept, in Carton Pack, is able to offer full support in the development of paper/cardboard packaging from the concept, to the engineering process and the elaboration of custom graphics.

PAPER PRODUCTS:	CARDBOARD AND MICRO CORRUGATED CARTON PRODUCTS:	CORRUGATED CARTON PRODUCTS:
BAGS SHOPPERS POUCHES AND PURSES PARCHMENTS and TISSUES PAPER BOTTOM CAPS ADHESIVE LABELS TABS	BASKETS (with/without handle) TRAYS BOXES PUNCHED CONTAINERS DECO BANDS	PLATEAUX TRAYS BOXES DISPLAYS PUNCHED CONTAINERS

CARTON PACK S.r.l. © January 2016  
All rights reserved

Images and design by  
Marketing Dept. - Carton Pack S.r.l.

Published on January 2016  
c/o Ragusa Grafica Moderna - Bari

I dati contenuti nel catalogo sono suscettibili di variazioni legate a esigenze tecniche e/o produttive. Le immagini sono puramente rappresentative.  
The data included in this catalogue are subject to change according to technical and/or production reasons. All images are purely representative.





Via Adelfia Z.I. • 70018 Rutigliano (Ba) Italy • Tel. +39 0804771440 Fax +39 0804771420 • [info@cartonpack.com](mailto:info@cartonpack.com) • [@cartonpack](https://www.cartonpack.com)

