

최고 품질의 포장용기 생산업체 PRODUCTS LIST SHINKWANG M&P

최고 품질의 포장용기 생산업체 PRODUCTS LIST SHINKWANG M&P Ver 1.0

SHINKWANG M&P PRODUCTS LIST Ver.1.0



- HB
- PPD
- PET
- PE
- PP
- PS

Best Value, Better Life

Shinkwang Mold & Plastic

History 연혁

- 1976** 07. 신한화학설립
- 업종 : 제조(플라스틱용기)
- 소재지 : 서울시 성북구 하월곡동 62-6
- 1985** 08. 공장이전
- 부천시 원미구 약대동 177-38
- 1989** 11. 상호변경
- 신광화학 공업사
- 1995** 12. 자가공장매입
- 경기도 부천시 원미구 도당동 159-1
- 1996** 01. 법인전환
- (주)신광화학 대표이사 정상열
- 식품용기 및 포장지 제조업 허가
- 2004** 03. ISO 9001:2000 및 KS A 9001:2001 인증획득
- 2008** 10. (주)신광화학 진천제1공장 매입
- 대지 : 4,515㎡, 건평 : 1,446.09㎡
- 충북 진천군 덕산면 인산리 173-2(대형용기 전문생산)
- 2009** 11. 진천제1공장 증축
- (지상2층)
- 연건평 : 1,893.54㎡
- 2010** 12. 금형기술연구소 설립
- 부천시 원미구 도당동 159-18번지
- 2010** 12. 크린룸 설치(진천공장)
- 1층(생산시설) 946.77㎡, 2층(인쇄시설) 946.77㎡
- 2013** 07. 상호변경
- (주)신광엠앤피(Mold &Plastic)
- 2014** 11. 오정동 본사공장 신축 준공 및 이전
- 경기도 부천시 오정구 오정동 770-1번지
- 연 면적(10,635.34㎡)
- 2015** 05. 의료기기 제조업 허가
- 2015** 06. 의료기기 제조 및 품질관리 기준 적합인정서 인증(KGMP)

Production institution

생산조직부서 소개



Injection Molding Dept. 사출 성형부



Silk printing, Labelling, Hot stamping Dept. 인쇄부



Assembly Dept. 조립부



Quality Control Dept. 품질관리부



Mold Dept. 금형부



R&D Center. 기술연구소

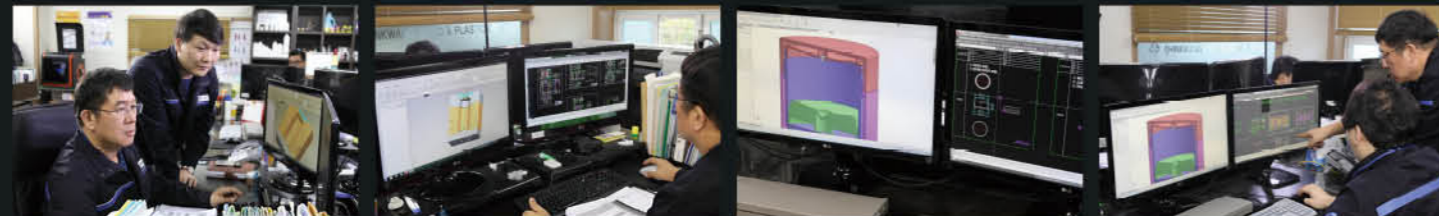

Injection & Direct Blowing Dept. 블로우 용기 성형부



스타입

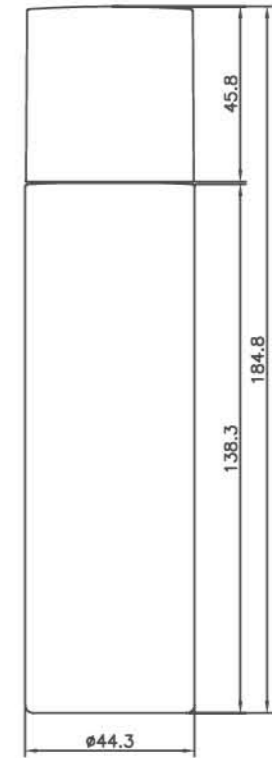

HAS-150

품번	재질	용량(ml)	외경(φ)	높이(mm)
60150-041	외캡 PCTA / 내캡 PP / 용기 PET	150	44.3	184.8



HA-130

품번	재질	용량(ml)	토출량(cc)	외경(∅)	높이(mm)
60130-041	오버캡 PCTA / 버튼 PP / 펌프 PP / 숄더캡 ABS / 용기 PET	130	0.3	42.6	177.7

HA-50

품번	재질	용량(ml)	토출량(cc)	외경(∅)	높이(mm)
60050-041	오버캡 PCTA / 버튼 PP / 펌프 PP / 숄더캡 ABS / 용기 PET	50	0.2	35.2	129.7



HAC-50

품번	재질	용량(ml)	외경(∅)	높이(mm)
60050-061	외캡 AS / 내캡 PP / 리드 PE / 내용기 PP / 외용기 PET	50	72	57.3

HAC-30

품번	재질	용량(ml)	외경(∅)	높이(mm)
60030-061	외캡 AS / 내캡 PP / 리드 PE / 내용기 PP / 외용기 PET	30	72	57.3

타입



HBS-150

품번	재질	용량(ml)	외경(φ)	높이(mm)
60150-051	외캡 PCTA / 내캡 PP / 용기 PET	150	49.9	178.4



HB-130

품번	재질	용량(ml)	토출량(cc)	외경(∅)	높이(mm)
60130-051	오버캡 PCTA / 버튼 PP / 펌프 PP / 숄더캡 ABS / 용기 PET	130	0.3	47.9	170.7

HB-50

품번	재질	용량(ml)	토출량(cc)	외경(∅)	높이(mm)
60050-051	오버캡 PCTA / 버튼 PP / 펌프 PP / 숄더캡 ABS / 용기 PET	50	0.2	42.8	116.3

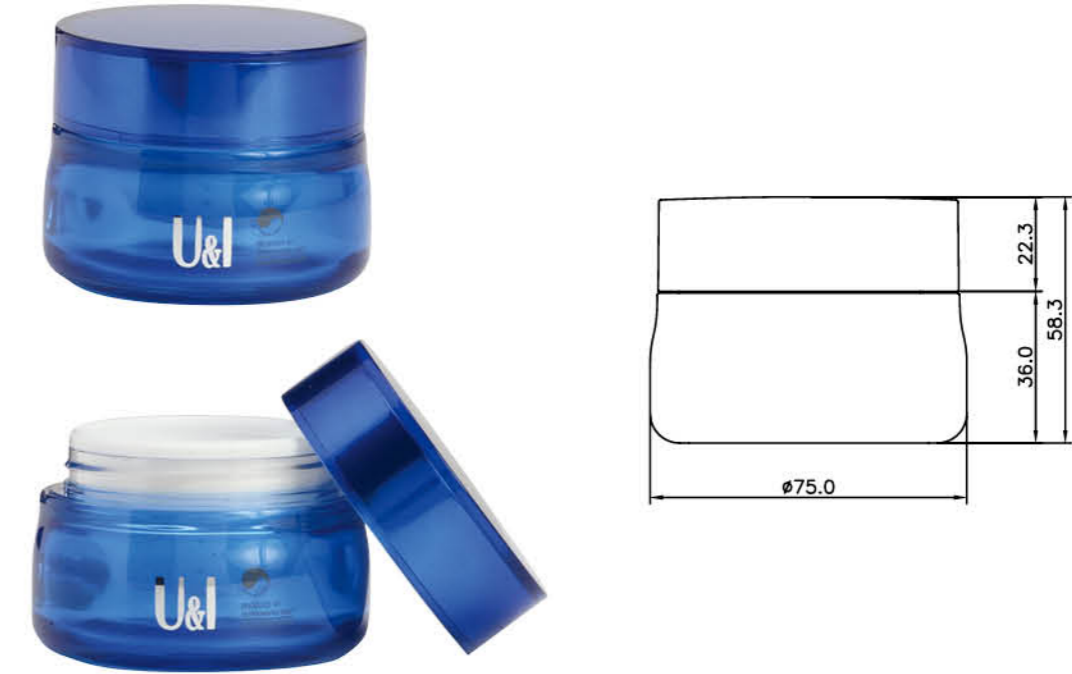

HBC-30

품번	재질	용량(ml)	외경(∅)	높이(mm)
60030-071	외캡 AS / 내캡 PP / 리드 PE / 내용기 PP / 외용기 PET	30	75	58.3

HBC-50

품번	재질	용량(ml)	외경(∅)	높이(mm)
60050-071	외캡 AS / 내캡 PP / 리드 PE / 내용기 PP / 외용기 PET	50	75	58.3

타입



HRS-150

품번	재질	용량(ml)	외경(φ)	높이(mm)
60150-012	외캡 PCTA / 내캡 PP / 용기 PET	150	46	165.8



HR-150

품번	재질	용량(ml)	토출량(cc)	외경(∅)	높이(mm)
60150-011	오버캡 PCTA / 버튼 PP / 펌프 PP / 솔더캡 ABS / 용기 PET	150	0.2	46	177.1



HR-50

품번	재질	용량(ml)	토출량(cc)	외경(∅)	높이(mm)
60050-011	오버캡 PCTA / 버튼 PP / 펌프 PP / 솔더캡 ABS / 용기 PET	50	0.2	40.3	118.8



HRC-50

품번	재질	용량(ml)	외경(∅)	높이(mm)
60050-031	외캡 PETG, SAN / 내캡 PP / 리드 PE / 내용기 PP / 외용기 SAN	50	69.2	52.8



HRC-30

품번	재질	용량(ml)	외경(∅)	높이(mm)
60030-031	외캡 PETG, SAN / 내캡 PP / 리드 PE / 내용기 PP / 외용기 SAN	30	70	42.8

유선형



HU-120

품번	재질	용량(ml)	토출량(cc)	외경(φ)	높이(mm)
60120-021	오버캡 PCTA / 버튼 PP / 펌프 PP / 솔더캡 ABS / 용기 PET	120	0.2	46	180.4



HU-60

품번	재질	용량(ml)	토출량(cc)	외경(∅)	높이(mm)
60060-021	오버캡 PCTA / 버튼 PP / 펌프 PP / 솔더캡 ABS / 용기 PET	60	0.2	40.3	133



HUC-50

품번	재질	용량(ml)	외경(∅)	높이(mm)
60050-031	외캡 PETG, SAN / 내캡 PP / 리드 FE / 내용기 PP / 외용기 SAN	50	69.2	52.8



HUC-30

품번	재질	용량(ml)	외경(∅)	높이(mm)
60030-031	외캡 PETG, SAN / 내캡 PP / 리드 FE / 내용기 PP / 외용기 SAN	30	70	42.8

디자인

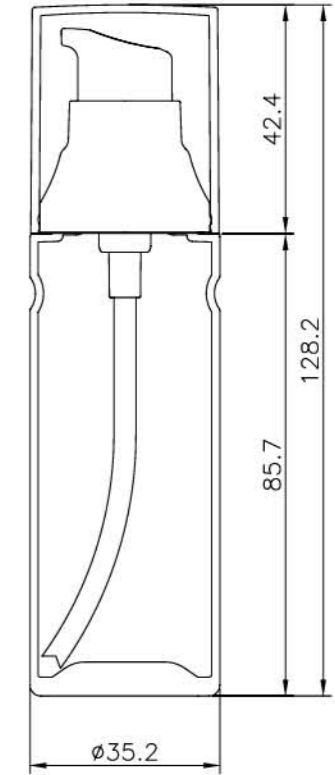

HD-50

품번	재질	용량(ml)	토출량(cc)	외경(φ)	높이(mm)
60050-091	오버캡 PETG / 버튼 PP / 펌프 PP / 솔더캡 PP / 용기 PET	50	0.2	35.2	128.2

스포이드



SPD-30



품번	재질	용량(ml)	외경(Ø)	높이(mm)
60030-111	티트 Silicone, NBR / 내캡 PP / 와이퍼 PE / 피펫 Glass / 용기 PET	30	40.8	105.2

SPD-50



품번	재질	용량(ml)	외경(Ø)	높이(mm)
60050-111	티트 Silicone, NBR / 내캡 PP / 와이퍼 PE / 피펫 Glass / 용기 PET	50	45.1	112.1

에어리스



AIR-50

품번	재질	용량(ml)	토출량(cc)	외경(Ø)	높이(mm)
60050-081	오버캡 PETG / 버튼 PP / 펌프 PP / 솔더캡 ABS / 내용기 PP / 외용기 PETG	50	0.2	37.4	151.1

스페셜크림

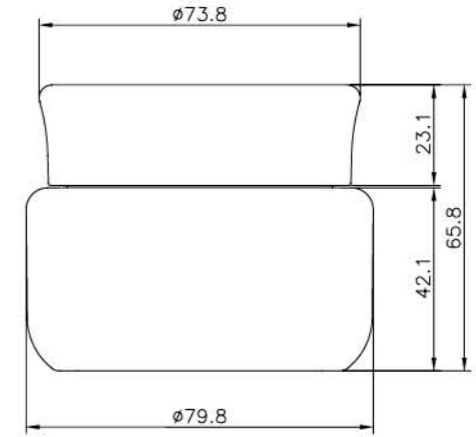

INI-50

품번	재질	용량(ml)	외경(Ø)	높이(mm)
60050-131	외캡 PETG, SAN / 내캡 PP / 리드 PE / 내용기 PP / 외용기 PET	50	79.8	65.8

파운데이션



FOD-30

품번	재질	용량(ml)	외경(∅)	높이(mm)
60030-101	오버캡 PETG / 버튼 PP / 펌프 PP / 용기 PE	30	35.9	86.1



FOD-50

품번	재질	용량(ml)	외경(∅)	높이(mm)
60050-101	오버캡 PETG / 버튼 PP / 펌프 PP / 용기 PE	50	35.9	106.1

HB

플링핀용기



BOL-300

품번	재질	용량(ml)	토출량(cc)	외경(∅)	높이(mm)
60300-151	오버캡 PETG / 버튼 PP / 펌프 PP / 숄더캡 ABS / 용기 PET	300	0.3	67.4	187.1

HB

단용기



HIS-50

품번	재질	용량(ml)	외경(∅)	높이(mm)
60050-121	외캡 AS / 내캡 ABS / 용기 PET	50	60	50.9

최고 품질의 포장용기 생산업체 PRODUCTS LIST
SHINKWANG M&P

PPD Series

글로벌시대에 국내 포장재산업을 선도하는
㈜신광M&P는 양질의 금형 설계 제작과
우수한 기술력으로 최고 품질의 포장용기를
생산하고 있습니다.



내용물을 남김없이 끝까지 사용 가능한
펌핑디스펜서 용기는 내용물 안에 기포
없이 미세한 토출량을 조절하는 기능성
에어리스 펌프로 국내, 국제특허를 취득
한 제품입니다.

펌핑디스펜서

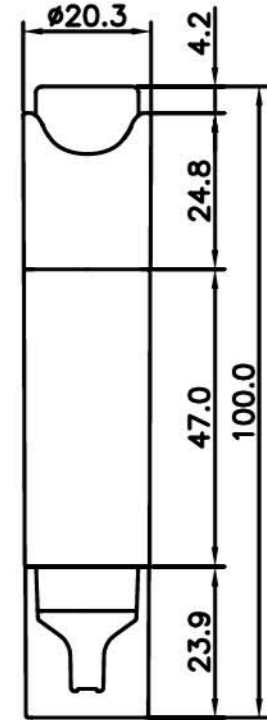

PPD-5

품번	재질	용량(ml)	외경(∅)	높이(mm)
60005-141	버튼 ABS / 펌프(이중사출) PP,TPR+TPE / 용기 PP / 오버캡 PP / 명판 PP	5	20.3	100

PPD

펌핑디스펜서

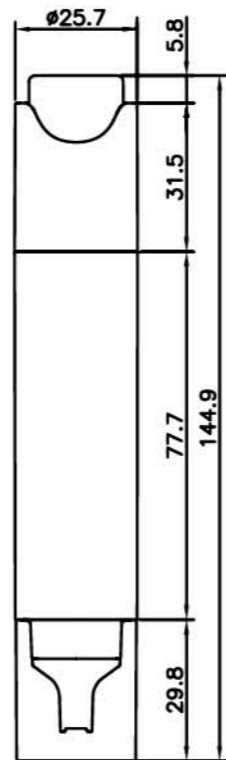

PPD-15

품번	재질	용량(ml)	외경(∅)	높이(mm)
60015-141	버튼 ABS / 펌프캡 ABS / 펌프(이중사출) PP, TPR+TPE / 내용기 PP / 외용기 PETG / 내캡 PP / 외캡 ABS	15	25.7	144.9

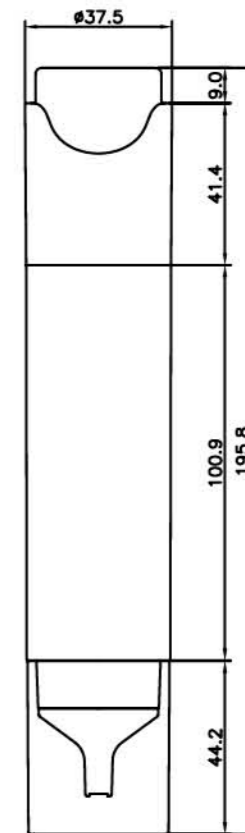

PPD-50

품번	재질	용량(ml)	외경(∅)	높이(mm)
60050-141	버튼 ABS / 펌프(이중사출) PP,TPR+TPE / 용기 PP / 오버캡 PP / 명판 PP	50	37.5	195.8

최고 품질의 포장용기 생산업체 PRODUCTS LIST
SHINKWANG M&P

PET Series

글로벌시대에 국내 포장재산업을 선도하는
(주)신광M&P는 양질의 금형 설계 제작과
우수한 기술력으로 최고 품질의 포장용기를
생산하고 있습니다.



PET-031 시리즈



PET-061 시리즈



PET-081 시리즈



PET-091 시리즈

PET 011 Series



품번	용량(ml)	형태	넥크(∅)	외경(∅)	높이(mm)
20050-011	50	원형	20	34.0	83.0
20060-011	60	원형	20	36.4	88.7
20060-012	60	원형	20	31.6	103.9
20100-011	100	원형	20	41.5	107.5
20150-011	150	원형	24	45.3	133.8
20200-011	200	원형	24	48	152.9
20250-011	250	원형	24	38.2	172.5
20260-011	260	원형	24	46.4	190



품번	용량(ml)	형태	넥크(∅)	외경(∅)	높이(mm)
20300-011	300	원형	24	50.5	188.6
20400-011	400	원형	24	56.5	200.3
20400-012	400	원형	28	56.2	200.3
20500-011	500	원형	28	61.2	216.5
20750-011	750	원형	32	75.6	203.8
20900-011	900	원형	32	82.7	211
21000-011	1000	원형	32	80.2	252.4

PET

PET 021 Series



품번	용량(ml)	형태	넥크(∅)	외경(∅)	높이(mm)
20100-021	100	원형	20	41.8	109.7
20150-021	150	원형	24	47.8	123.8
20200-021	200	원형	24	52.9	134.2
20250-021	250	원형	24	56.5	145.1
20300-021	300	원형	24	60.4	151
20400-021	400	원형	24	66	163.1
20500-021	500	원형	28	71.1	177.8



품번	용량(ml)	형태	넥크(∅)	외경(∅)	높이(mm)
20500-022	500	원형	32	71.1	177.5
20700-021	700	원형	32	79.5	193.3
21000-021	1000	원형	32	89.9	211.4
20300-022	300	원형	34	52.7	188.1
20500-023	500	원형	32	62.0	216.2
21500-021	1500	원형	38	95.1	285.4

PET
031
Series



품번	용량(ml)	형태	넥크(∅)	외경(∅)	높이(mm)
20100-031	100	원형	20	42.3	104.8
20150-031	150	원형	24	48.5	118
20200-031	200	원형	24	53	128.4
20250-031	250	원형	24	57	138
20300-031	300	원형	24	60.6	144.5



품번	용량(ml)	형태	넥크(∅)	외경(∅)	높이(mm)
20400-031	400	원형	24	66.58	157.9
20400-032	400	원형	28	66.58	157.9
20500-031	500	원형	32	71	164.9
20700-031	700	원형	32	80.1	182.9
21000-031	1000	원형	32	89.7	203.3

PET

PET 041 Series



품번	용량(ml)	형태	넥크(∅)	외경(∅)	높이(mm)
20200-041	200	원형	24	59.8	107.5
20250-041	250	원형	24	64	114.7
20300-041	300	원형	24	68.3	119.7
20400-041	400	원형	28	74.5	130.8
20500-041	500	원형	32	82.5	133.2
20750-041	750	원형	32	93.3	150.4
21000-041	1000	원형	32	102.3	163.3

PET 051 Series



품번	용량(ml)	형태	넥크(∅)	외경(∅)	높이(mm)
20005-051	5	원형	10	19	38.1
20008-051	8	원형	10	18.8	51
20030-051	30	원형	17	27.6	80.7
20032-051	32	원형	17	26.2	87.5
20034-051	34	원형	17	26.4	90.9
20045-051	45	원형	20	31	101.6

PET 051 Series



품번	용량(ml)	형태	넥크(∅)	외경(∅)	높이(mm)
20045-051	45 (20℄)	원형	20	33.6	83.6
20050-051	50 (18℄)	원형	17	33	85
20070-051	70	원형	17	33.1	119.3
20140-051	140	원형	24	42.7	135.9
20150-051	150	원형	24	47.7	114.8
20200-051	200	원형	24	53	126
20220-051	220	원형	24	49.7	142.7



품번	용량(ml)	형태	넥크(∅)	외경(∅)	높이(mm)
20240-051	240	원형	24	50.7	159.6
20350-051	350	원형	28	36.5	148.2
20410-051	410	원형	28	61.8	176.9
20450-051	450	원형	32	75.6	129.7
20500-051	500	원형	32	75.8	140.8
20500-052	500	원형	28	76	141.5

PET

PET 051 Series



품번	용량(ml)	형태	넥크(∅)	외경(∅)	높이(mm)
20800-051	800	원형	32	74	222
21000-051	1000	원형	32	80.3	238.9
21000-052	1000	원형	32	80.3	238.9
21150-051	1150	원형	32	90.5	211.4
21500-051	1500	원형	32	101.1	269



품번	용량(ml)	형태	넥크(∅)	외경(∅)	높이(mm)
21000-053	1000	원형	32	26.3	248.6
21500-052	1500	원형	38	101.1	269
20400-052	400	원형	24	65.3	200.2
20150-052	150	원형	24	43.7	139
20300-051	300	원형	24	48.8	165.5
20550-051	550	원형	28	61.7	211

PET 061 Series



품번	용량(ml)	형태	넥크(∅)	외경(∅)	높이(mm)
20120-061	120	원형	24	48.6	90.7
20150-061	150	원형	20	46.3	119
20160-061	160	원형	24	48.1	120.5
20200-061	200	원형	24	52.8	122.6
20250-061	250	원형	24	57.6	128.4
20280-061	280	원형	24	58.1	138.5
20300-061	300	원형	24	61.6	135.7



품번	용량(ml)	형태	넥크(∅)	외경(∅)	높이(mm)
20300-062	300	원형	24	61	136
20300-063	300	원형	24	57.1	151.7
20400-061	400	원형	28	68.8	177.5
20410-061	410	원형	32	67.9	147.1
20500-061	500	원형	32	65.8	193.4
20500-062	500	원형	28	65.3	193.8
20550-061	550	원형	32	68	196

PET 071 Series



품번	용량(ml)	형태	넥크(∅)	외경(∅)	높이(mm)
20100-071	100	원형	20	39.5	122
20150-071	150	원형	24	45.5	131.7
20200-071	200	원형	24	50	143.8
20250-071	250	원형	24	53.9	152.8
20300-071	300	원형	24	57.5	161.7
20400-071	400	원형	28	63.4	178.4



품번	용량(ml)	형태	넥크(∅)	외경(∅)	높이(mm)
20500-071	500	원형	28	66.5	189
20650-071	650	원형	32	72.6	204
20750-071	750	원형	32	75.9	215
20850-071	850	원형	32	79.2	223
21000-071	1000	원형	32	93.3	240

PET

081 Series



품번	용량(ml)	형태	넥크(∅)	외경(∅)	높이(mm)
20060-081	60	타원	20	42.4	101.3
20100-081	100	타원	20	31.3	119
20200-081	200	타원	24	64.5	150.2
20300-081	300	타원	24	47	161.6
20430-081	430	타원	28	78.4	180.6
20550-081	550	타원	32	55	190.4
20750-081	750	타원	32	93.1	210.1
21000-081	1000	타원	32	101.8	229.6



품번	용량(ml)	형태	넥크(∅)	외경(∅)	높이(mm)
20200-082	200	타원	24	61.6	128.8
20250-081	250	타원	24	66.6	137.4
20500-081	500	타원	28	60.6	184.5
21000-082	1000	타원	32	112.3	217.4
20250-082	250	타원	24	41.7	170

PET 081 Series



품번	용량(ml)	형태	넥크(∅)	외경(∅)	높이(mm)
20060-082	60	타원	20	44.7	91.7
20150-081	150	타원	24	55.8	141.8
20500-082	500	타원	28	90.4	196.3
20550-082	550	타원	32	56.4	209.4
20750-082	750	타원	32	92.9	209.8
20850-081	850	타원	32	67.3	229.2
21000-083	1000	타원	32	101.9	229.1



품번	용량(ml)	형태	넥크(∅)	외경(∅)	높이(mm)
20300-083	300	타원	40	59	120
20300-084	300	타원	28	59	120
20500-083	500	타원	42	78.8	132
20500-084	500	타원	32	78.8	132

PET 091 Series



품번	용량(ml)	형태	넥크(∅)	외경(∅)	높이(mm)
20030-092	30	사각	14	23.7	72.7
20030-091	30	사각	14	35.7	72.3
20100-091	100	사각	20	54.2	88.1
20200-091	200	사각	24	58.3	139
20300-091	300	사각	24	71.7	177.2
20400-091	400	사각	28	83	152.3
20045-091	45	사각	18	31.5	81.6



품번	용량(ml)	형태	넥크(∅)	외경(∅)	높이(mm)
20140-091	140	사각	20	35.3	162.6
20100-092	100	사각	20	38.1	115.8
20150-091	150	사각	24	43.5	130.4
20250-091	250	사각	24	51.3	150.9
20350-091	350	사각	28	57.1	168.4
20300-092	300	사각	24	48.5	164

PET

PET 091 Series



품번	용량(ml)	형태	넥크(∅)	외경(∅)	높이(mm)
20500-091	500	사각	32	60.1	151
21000-091	1000	사각	32	71.5	220
20500-092	500	사각	32	66	151
20060-091	60	사각	22	26.2	84.9
20300-093	300	사각	24	55.6	148.2
20350-092	350	사각	24	58.8	156



품번	용량(ml)	형태	넥크(∅)	외경(∅)	높이(mm)
20550-091	550	사각	28	68.3	182.5
20600-091	600	사각	32	68.6	183
20250-092	250	사각	24	67	115.9
20300-096	300	사각	28	71.3	123.1
20500-093	500	사각	32	57.9	198.5
20300-095	300	사각	24	42.7	187

PET

101 Series



품번	용량(ml)	형태	넥크(∅)	외경(∅)	높이(mm)
20075-101	75	원형	17	40.5	103.9
20145-101	145	원형	17	50.8	132.4
20290-101	290	원형	24	63.8	168.6
20150-101	150	원형	24	70.8	75.5
20150-102	150	원형	24	67.6	91
20200-101	200	원형	24	77.1	81.7
20200-102	200	원형	24	79.9	105.2
20250-101	250	원형	24	83.2	86.3
20250-102	250	원형	24	79.9	105.2

PET

111 Series

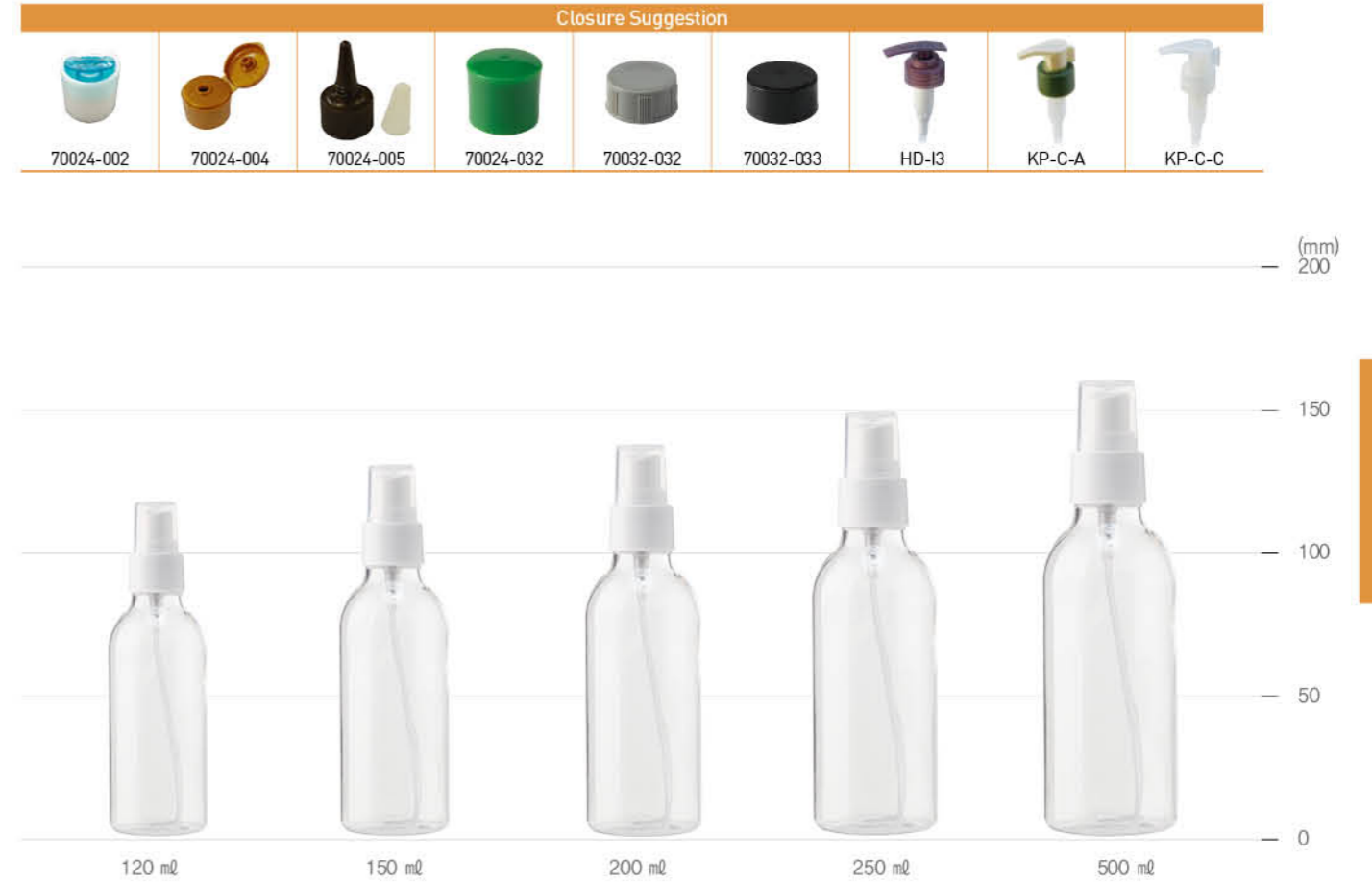

품번	용량(ml)	형태	넥크(∅)	외경(∅)	높이(mm)
20120-111	120	원형	24	43.2	118
20150-111	150	원형	24	46.2	129
20200-111	200	원형	24	50.2	144
20250-111	250	원형	24	54.5	158
20500-112	500	원형	32	76	157.3

PET
111
Series



품번	용량(ml)	형태	넥크(∅)	외경(∅)	높이(mm)
20400-111	400	원형	32	75.5	148.2
20500-111	500	원형	32	71.5	175.8
20500-117	500	원형	32	71.2	189.4
20750-112	750	원형	32	78.6	211.4

PET
131
Series



품번	용량(ml)	형태	넥크(∅)	외경(∅)	높이(mm)
20500-131	500	타원	28	100.5	222.6
20530-131	530	타원	28	105.5	226
20670-131	670	타원	28	110	227.4

PET

141 Series



품번	용량(ml)	형태	넥크(∅)	외경(∅)	높이(mm)
20100-141	100	원형	22	38.3	117.7
20150-141	150	원형	22	45.8	130.2
20150-144	150	원형	22	41.8	155.6

PET

151 Series



품번	용량(ml)	형태	넥크(∅)	외경(∅)	높이(mm)
21000-151	1 KG	원형	89.2	126.2	102.6
22000-151	2 KG	원형	119.6	159.4	130.1
23000-151	3 KG	원형	119.6	179.4	148.5
25000-151	5 KG	원형	119.8	198.1	194.3

PET

161 Series



품번	용량(ml)	형태	넥크(∅)	외경(∅)	높이(mm)
20100-161	100	JAR	68.6	73.7	37.2
20150-161	150	JAR	83.2	89.4	36.8
20200-161	200	JAR	98.9	103	38.5
20300-161	300	JAR	88	94.2	57
20400-161	400	JAR	104.1	109.7	56.3
20500-161	500	JAR	104.1	66.7	109.5



품번	용량(ml)	형태	넥크(∅)	외경(∅)	높이(mm)
20055-161	55	JAR	40.3	53.5	41.3
20160-161	160	JAR	71	76.5	49.9
20200-162	200	JAR	83.5	89.4	45.6
20230-161	230	JAR	68.4	84.9	57.7

PET

171 Series

Closure Suggestion



품번	용량(ml)	형태	넥크(Ø)	외경(Ø)	높이(mm)
20150-171	150	타원	24	53.2	133.9
20200-171	200	타원	24	62.3	154.3
20500-171	500	타원	28	79.2	193.9

최고 품질의 포장용기 생산업체 PRODUCTS LIST
SHINKWANG M&P

PE Series

글로벌시대에 국내 포장재산업을 선도하는 (주)신광M&P는 양질의 금형 설계 제작과 우수한 기술력으로 최고 품질의 포장용기를 생산하고 있습니다.



PE-011 시리즈



PE-021 시리즈



PE-031 시리즈



PE-141 시리즈



PE-151 시리즈

PE
011
Series



품번	용량(ml)	형태	넥크(∅)	외경(∅)	높이(mm)
10045-011	45	원형	24	32.3	91.2
10080-011	80	원형	24	34.6	120.7
10100-011	100	원형	24	37.5	130.5
10100-012	100	원형	24	35.7	125
10130-011	130	원형	20	41.5	122
10140-011	140	원형	24	38.7	153.9



품번	용량(ml)	형태	넥크(∅)	외경(∅)	높이(mm)
10180-011	180	원형	24	47.6	141.3
10240-011	240	원형	24	49	169.5
10300-012	300	원형	24	51	188
10500-011	500	원형	24	63.2	199.5
10800-012	800	원형	32	76.3	238
11000-011	1000	원형	32	80	243.5

PE
011
Series



품번	용량(ml)	형태	넥크(∅)	외경(∅)	높이(mm)
11500-011	1500	원형	38	96	263.4
12000-011	2000	원형	38	106	277.5
10150-012	150	원형	24	44.6	133.2

PE
021
Series



품번	용량(ml)	형태	넥크(∅)	외경(∅)	높이(mm)
10030-021	30	원형	18	30.5	76.3
10120-021	120	원형	20	41	128.4
10150-021	150	원형	17	42.5	145.7
10150-022	150	원형	24	43.5	149
10200-021	200	원형	24	47	160
10200-022	200	원형	24	47	161

PE 021 Series



품번	용량(ml)	형태	넥크(∅)	외경(∅)	높이(mm)
10200-023	200	원형	24	57.5	113.9
10250-021	250	원형	24	56.8	133
10250-022	250	원형	24	50.5	170.2
10250-023	250	원형	24	47.9	185.1
10300-021	300	원형	28	66	125.7
10300-022	300	원형	24	51.6	188.5
10300-023	300	원형	43	60.5	149



품번	용량(ml)	형태	넥크(∅)	외경(∅)	높이(mm)
10400-021	400	원형	28	59.8	185
10500-021	500	원형	28	60	220.6
10750-021	750	원형	32	77.3	205.1
11000-021	1000	원형	32	81	252.2
11000-022	1000	원형	32	80.7	256.7
11000-024	1000	원형	32	92.2	197
11500-021	1500	원형	32	95.6	286.8

PE
021
Series



품번	용량(ml)	형태	넥크(∅)	외경(∅)	높이(mm)
10020-021	20	원형	18	30.2	58.9
10030-021	30	원형	18	30.5	76.3
10150-023	150	원형	24	53.9	102.8
10150-024	150	원형	24	49.8	127.6
10500-023	500	원형	27	82.3	145.7
10500-022	500	원형	32	69.4	198

PE
031
Series



품번	용량(ml)	형태	넥크(∅)	외경(∅)	높이(mm)
10200-031	200	타원	24	40.7	152.3
10380-031	380	타원	28	74.3	167
10400-031	400	타원	27	84	180
10300-031	300	타원	28	89.7	149.7
10780-031	780	타원	32	93.8	203

PE

PE
051
Series



품번	용량(ml)	형태	넥크(∅)	외경(∅)	높이(mm)
10160-051	160	원형	24	45.5	119.7
10180-051	180	원형	24	45.7	127.6
10240-051	240	원형	30	50.5	157.2
10100-051	100	원형	24	43.1	102.2

PE
091-101
Series



※ Available In-mold Label

품번	용량(ml)	형태	넥크(∅)	외경(∅)	높이(mm)
10100-091	100	원형	37	51.1	80.8
10160-091	160	원형	37	53.9	98.1
10650-101	650	타원	49.3	70.6	158.5
11300-101	1300	타원	49.3	91.9	183.1
11800-101	1800	타원	49.3	99.4	208.5

PE
111-121
Series



※ Available In-mold Label

품번	용량(ml)	형태	넥크(∅)	외경(∅)	높이(mm)
12500-111	2500	세제	38	97.5	287
13500-111	3500	세제	38	108.5	317
10550-121	550	세제	50	76.3	213
10500-121	500	세제	32	63.7	158.3



PE
131
Series



※ Available In-mold Label

품번	용량(ml)	형태	넥크(∅)	외경(∅)	높이(mm)
11000-131	1000	세제	58.8	89.2	201
11500-131	1500	세제	58.8	96.5	230
12000-131	2000	세제	58.8	102.8	256
12500-131	2500	세제	58.8	110	275

PE
131
Series



※ Available In-mold Label

품번	용량(㎖)	형태	넥크(∅)	외경(∅)	높이(mm)
13000-131	3000	세제	58.8	116	285
13500-131	3500	세제	58.8	122.6	299
14000-131	4000	세제	58.8	133.4	311

PE
141
Series



품번	용량(㎖)	계량컵	넥크(∅)	외경(∅)	높이(mm)	높이(mm)
15700-141	5700	66.1	38	32	244.8	257.8



최고 품질의 포장용기 생산업체 PRODUCTS LIST
SHINKWANG M&P

PP Series

글로벌시대에 국내 포장재산업을 선도하는 (주)신광M&P는 양질의 금형 설계 제작과 우수한 기술력으로 최고 품질의 포장용기를 생산하고 있습니다.



PP-011 시리즈



PP-022 시리즈



PP-031 시리즈

PP 011 Series

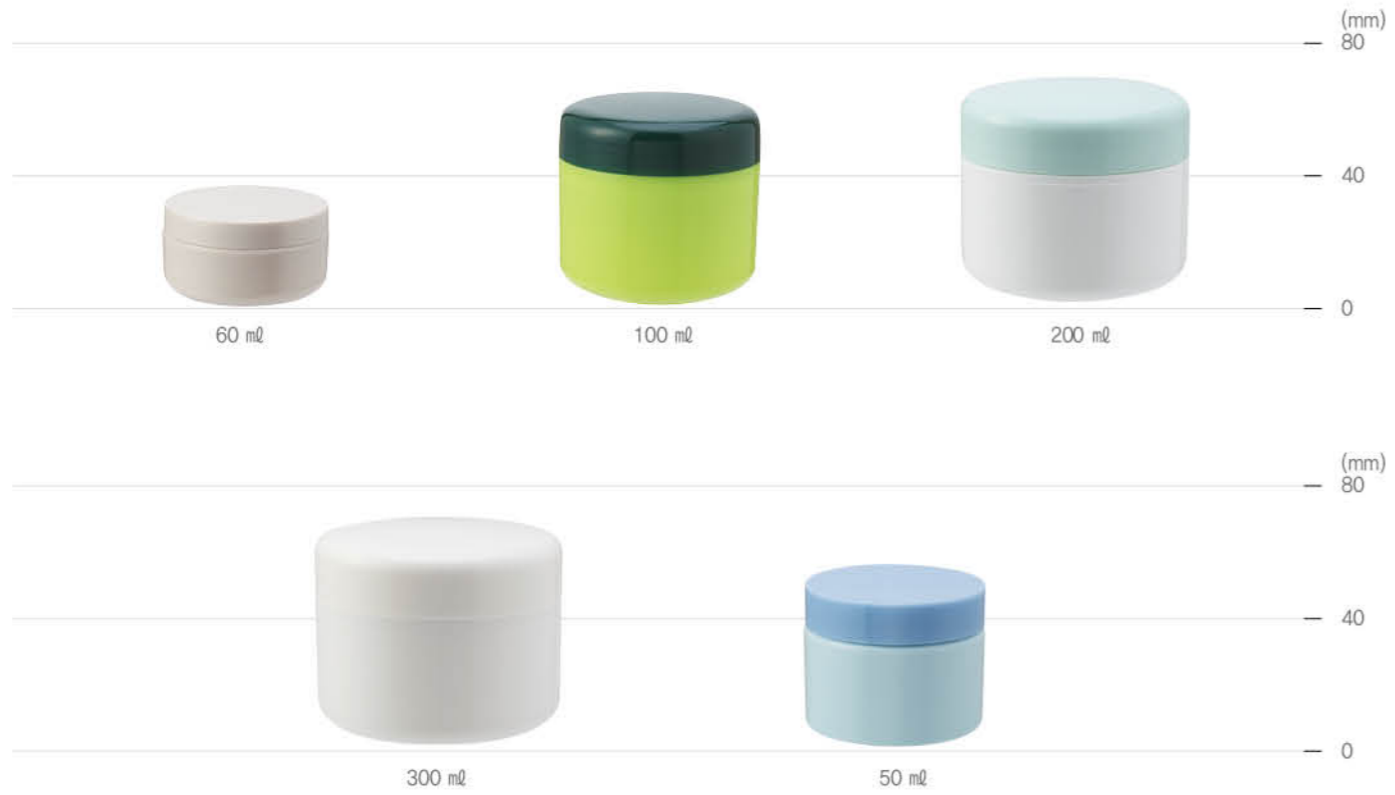

품번	용량(ml)	형태	넥크(∅)	외경(∅)	높이(mm)
40060-011	60	JAR	68	73	37.3
40100-011	100	JAR	70.1	73	63.4
40200-011	200	JAR	96.9	99.7	74.9
40300-011	300	JAR	96.8	84.3	76.2
40050-011	50	JAR	55.5	61	47

PP 021 Series



품번	용량(ml)	형태	넥크(∅)	외경(∅)	높이(mm)
40100-021	100	JAR	66	63.6	59
40150-021	150	JAR	66	63.6	69.2
40100-023	100	JAR	57.1	74.1	64.8
40050-021	50	JAR	69.3	80	31.6
40100-022	100	JAR	67.8	79.4	47
40200-021	200	JAR	83.1	94.7	56.3

PP
031-041
Series



품번	용량(ml)	형태	넥크(∅)	외경(∅)	높이(mm)
40500-031	500	JAR	102.4	101.2	77.5
40800-031	800	JAR	102.4	102.3	118.2
41000-031	1000	JAR	102.4	102.3	118.4
41200-031	1200	JAR	102.4	102.3	172
40500-041	500	JAR	94	98	118
41000-041	1000	JAR	103.1	108	172

PP
051
Series



품번	용량(ml)	형태	넥크(∅)	외경(∅)	높이(mm)
40100-051	100	JAR	55.8	64.5	65.8

최고 품질의 포장용기 생산업체 PRODUCTS LIST
SHINKWANG M&P

PS Series

글로벌시대에 국내 포장재산업을 선도하는 (주)신광M&P는 양질의 금형 설계 제작과 우수한 기술력으로 최고 품질의 포장용기를 생산하고 있습니다.





품번	용량(ml)	형태	넥크(∅)	지름(∅)	높이(mm)
50010-011	10	JAR	31.4	35.3	25.8
50050-011	50	JAR	69.4	73.3	24.7
50030-011	30	JAR	59.4	62.7	17.5
50080-011	80	JAR	64	68.5	41.2



품번	용량(ml)	형태	넥크(∅)	지름(∅)	높이(mm)
50110-011	110	JAR	77.4	82.9	38.2
50150-011	150	JAR	81.1	86.8	43.5
50300-011	300	JAR	81.2	86.5	81.7



250 ml



400 ml

(mm)
100
80
60
40
20
0

PS

품번	용량(ml)	형태	넙크(∅)	지름(∅)	높이(mm)
50250-021	250	JAR	84.1	86.4	63
50400-011	400	JAR	87.8	86	94.5

