

PRODUCT TITLE

**214ml CONDIMENT**

DRAWING NUMBER

**E1433-J-02** ...

ISSUE NUMBER

**3**

MATERIAL

**PET**

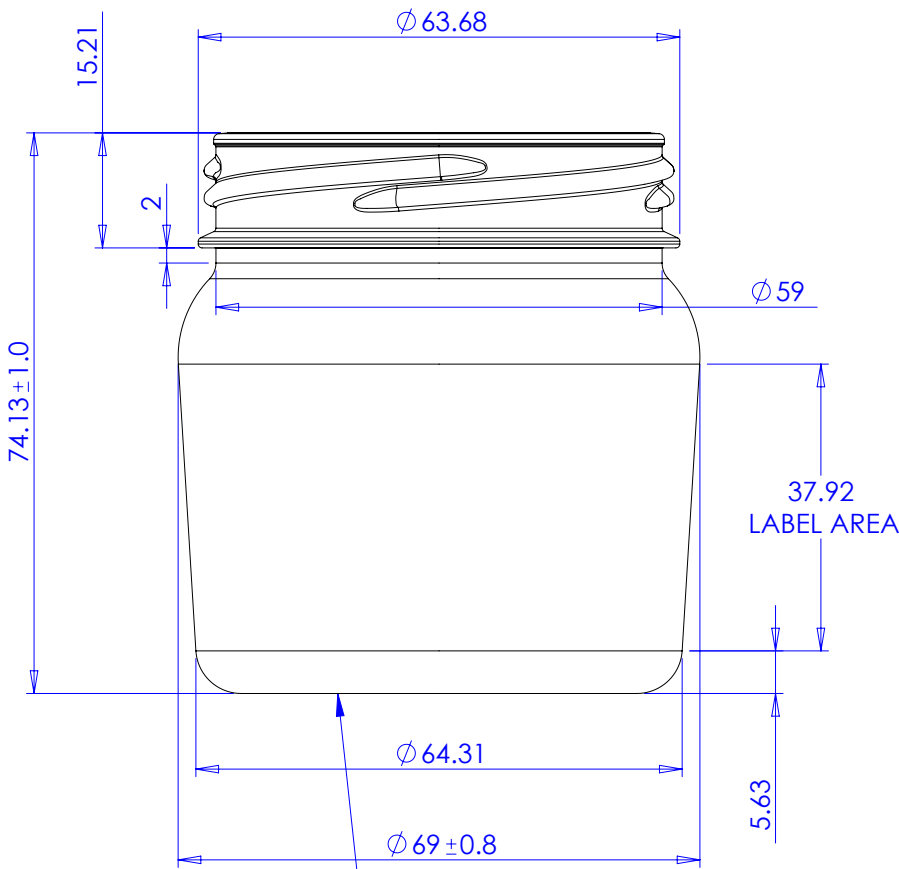

ESTERFORM LOGO  
RECYCLING LOGO  
AND CAVITY NUMBER  
TO BE SIZED AND POSITIONED  
APPROPRIATELY ON BASE

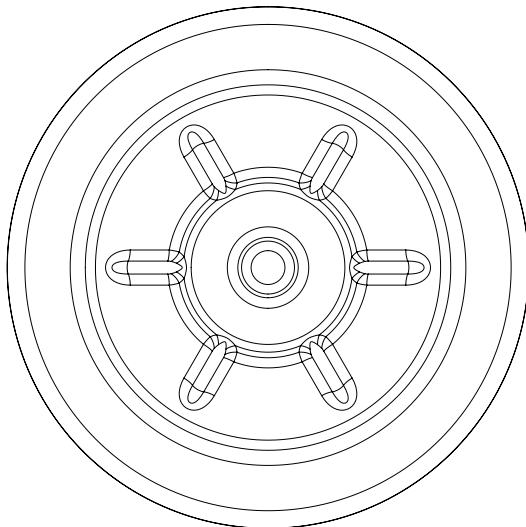

CAPACITY @ FILL LEVEL  
@ 20°C after 72hrs

...

CAPACITY @ BRIMFUL  
@ 20°C after 72hrs

**214ml ± 5ml**

NECK FINISH

**63mm ULTRA**

NECK DRAWING No

**E1388-N-02**

DESIGN WEIGHT

**26.5g**

ALTERNATIVE WEIGHTS

...

TOOLING REF

...

**DIMENSIONS**

ALL DIMENSIONS IN MILLIMETERS UNLESS OTHERWISE STATED

ALL DIMENSIONS SHOWN ARE A REPRESENTATION AND ARE SUBJECT TO CHANGE

UNLESS STATED GENERAL TOLERANCES FOR BLOWN PARTS = ±0.5 mm

UNLESS STATED GENERAL TOLERANCES FOR INJECTED PARTS = ±0.2mm

**HEAD OFFICE**

ESTERFORM PACKAGING LIMITED  
BORASTON LANE  
TENBURY WELLS  
WORCESTERSHIRE  
WR15 8LE, UK

Phone : +44 (0) 1584 810 600  
Fax : +44 (0) 1584 810 213

THIS DRAWING AND THE COPYRIGHT THEREON ARE THE PROPERTY OF ESTERFORM LTD AND MUST NOT BE REPRODUCED IN PART OR IN WHOLE OR PASSED ON TO OTHERS WITHOUT PERMISSION