

PRODUCT TITLE

500g JALAPENO

DRAWING NUMBER

E1475-J-02 ...

ISSUE NUMBER

3

MATERIAL

PET

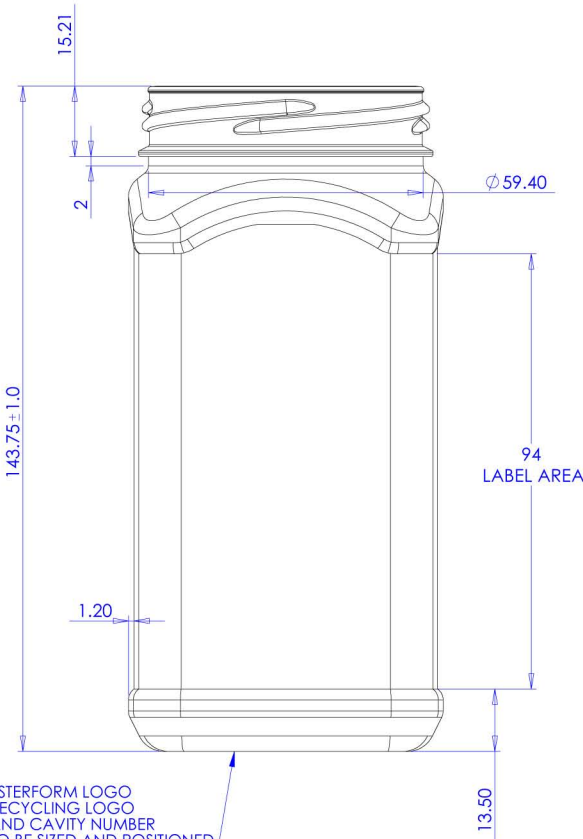

ESTERFORM LOGO
RECYCLING LOGO
AND CAVITY NUMBER
TO BE SIZED AND POSITIONED
APPROPRIATELY ON BASE

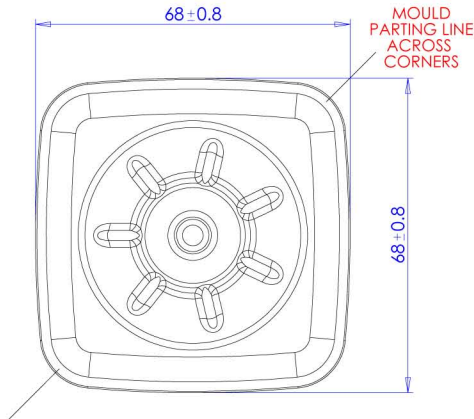

CAPACITY @ FILL LEVEL
@ 20°C after 72hrs

...

CAPACITY @ BRIMFUL
@ 20°C after 72hrs

**522 ± 5ml + expected
7ml bulge**

NECK FINISH

63mm ULTRA

NECK DRAWING No

E1388-N-02

DESIGN WEIGHT

38g

ALTERNATIVE WEIGHTS

46g

TOOLING REF

...

DIMENSIONS

ALL DIMENSIONS IN MILLIMETERS UNLESS
OTHERWISE STATED

ALL DIMENSIONS SHOWN ARE A REPRESENTATION
AND ARE SUBJECT TO CHANGE

UNLESS STATED GENERAL TOLERANCES
FOR BLOWN PARTS = ±0.5 mm

UNLESS STATED GENERAL TOLERANCES
FOR INJECTED PARTS = ±0.2mm

HEAD OFFICE

ESTERFORM PACKAGING LIMITED
BORASTON LANE
TENBURY WELLS
WORCESTERSHIRE
WR15 8LE, UK

Phone : +44 (0) 1584 810 600
Fax : +44 (0) 1584 810 213

THIS DRAWING AND THE COPYRIGHT THEREON
ARE THE PROPERTY OF ESTERFORM LTD AND MUST
NOT BE REPRODUCED IN PART OR IN WHOLE OR
PASSED ON TO OTHERS WITHOUT PERMISSION