

PRODUCT TITLE

710ml ROUND JAR

DRAWING NUMBER

E1653-J-02

ISSUE NUMBER

1

MATERIAL

PET

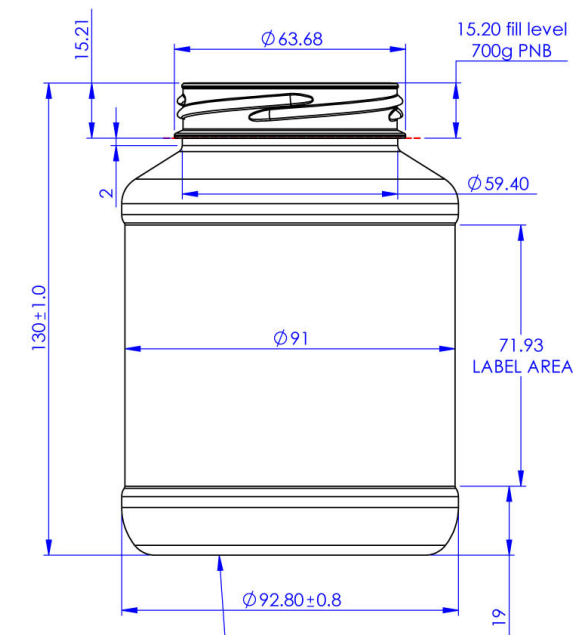

ESTERFORM LOGO
RECYCLING LOGO
AND CAVITY NUMBER
TO BE SIZED AND POSITIONED
APPROPRIATELY ON BASE

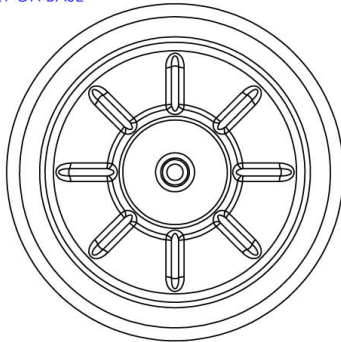

285.50

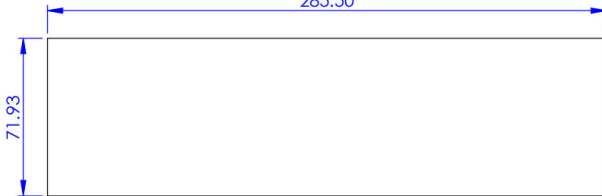

PROJECTED LABEL PANEL SIZE

CAPACITY @ FILL LEVEL
@ 20°C after 72hrs

SUBJECT TO
PRODUCT DENSITY

CAPACITY @ BRIMFUL
@ 20°C after 72hrs

710ml ± 8ml

NECK FINISH

63mm ULTRA

NECK DRAWING No

E1388-N-02

DESIGN WEIGHT

38g

ALTERNATIVE WEIGHTS

46g

TOOLING REF

...

DIMENSIONS

ALL DIMENSIONS IN MILLIMETERS UNLESS
OTHERWISE STATED

ALL DIMENSIONS SHOWN ARE A REPRESENTATION
AND ARE SUBJECT TO CHANGE

UNLESS STATED GENERAL TOLERANCES
FOR BLOWN PARTS = ±0.5 mm

UNLESS STATED GENERAL TOLERANCES
FOR INJECTED PARTS = ±0.2mm

HEAD OFFICE

ESTERFORM PACKAGING LIMITED
BORASTON LANE
TENBURY WELLS
WORCESTERSHIRE
WR15 8LE, UK

Phone : +44 (0) 1584 810 600
Fax : +44 (0) 1584 810 213

THIS DRAWING AND THE COPYRIGHT THEREON
ARE THE PROPERTY OF ESTERFORM LTD AND MUST
NOT BE REPRODUCED IN PART OR IN WHOLE OR
PASSED ON TO OTHERS WITHOUT PERMISSION